

# SLV-SE310/SE410/SE510

RMT-V257B/V257C

## SERVICE MANUAL



Photo: SLV-SE510

- Refer to the **SERVICE MANUAL of VHS MECHANICAL ADJUSTMENTS VI** for **MECHANICAL ADJUSTMENTS.** (9-921-647-11)

S MECHANISM

*AEP Model*  
SLV-SE310D/SE510B/D/SE510D

*UK Model*  
SLV-SE310I

*East European Model*  
*Russian Model*  
SLV-SE410K/SE510K

The abbreviations of SE310/SE410/SE510 contained in this service manual are indicated when these models are common to all their corresponding models as given below.

Abbreviated models name	SE310	SE410	SE510
All model names SLV-	SE310D SE310I	SE410K	SE510B SE510D SE510K

### SPECIFICATIONS

#### System

Channel coverage  
SLV-SE310I  
PAL (I)  
VHF IA to IJ, SA10 to SA13  
UHF B21 to B69  
CATV S01 to S05, S1 to S20  
HYPER S21 to S41  
SLV-SE410K/SE510K  
PAL (B/G, D/K)  
VHF E2-E12, R1-R12  
UHF E21-E69, R21-R69  
CATV S1-S41, S01-S05  
SLV-SE310D/SE510D  
PAL (B/G)  
VHF E2 to E12  
VHF Italian channel A to H  
UHF E21 to E69 0  
CATV S01 to S05, S1 to S2  
HYPER S21 to S41

#### SLV-SE510B

SECAM (L) : VHF F2 to F10  
UHF F21 to F69  
CATV B to Q  
HYPER S21 to S41  
PAL (B/G) : VHF E2 to E12  
VHF Italian channel A to H  
UHF E21 to E69  
CATV S01 to S05, S1 to S20  
HYPER S21 to S41  
RF output signal  
UHF channels 21-69  
Aerial out  
75-ohm asymmetrical aerial socket

#### Tape speed

SP: PAL/MESECAM  
23.39 mm/s (recording/playback)  
SECAM 23.39 mm/s  
(recording/playback)  
NTSC  
33.35 mm/s (playback only)  
LP: PAL/MESECAM  
11.70 mm/s (recording/playback)  
SECAM 11.70 mm/s  
(recording/playback)  
NTSC  
16.67 mm/s (playback only)  
EP: NTSC  
11.12 mm/s (playback only)

- Continued on next page -

**VHS** VIDEO CASSETTE RECORDER

**SONY**®

Maximum recording/playback time  
10 hrs. in LP mode (with E300 tape)  
Fast-forward and rewind time  
Approx. 3 min. (with E180 tape)

### Inputs and outputs

LINE-1 (TV)  
21-pin  
Video input: pin 20  
Audio input: pins 2 and 6  
Video output: pin 19  
Audio output: pins 1 and 3  
DECODER/ LINE-2 IN  
21-pin  
Video input: pin 20  
Audio input: pins 2 and 6

### General

Power requirements  
220 – 240 V AC, 50 Hz  
Power consumption  
18 W  
1.5 W (POWER SAVE is set to ON,  
minimum)  
Operating temperature  
5°C to 40°C  
Storage temperature  
–20°C to 60°C  
Dimensions  
Approx. 355 × 96 × 288 mm (w/h/d)  
including projecting parts and controls  
Mass  
Approx. 3.7 kg

### Supplied accessories

Remote commander (1)  
R6 (size AA) batteries (2)  
Aerial cable (1)

Design and specifications are subject to  
change without notice.

### SAFETY-RELATED COMPONENT WARNING!!

COMPONENTS IDENTIFIED BY MARK  $\triangle$  OR DOTTED LINE WITH MARK  $\triangle$  ON THE SCHEMATIC DIAGRAMS AND IN THE PARTS LIST ARE CRITICAL TO SAFE OPERATION. REPLACE THESE COMPONENTS WITH SONY PARTS WHOSE PART NUMBERS APPEAR AS SHOWN IN THIS MANUAL OR IN SUPPLEMENTS PUBLISHED BY SONY.

## SAFETY CHECK-OUT

After correcting the original service problem, perform the following safety checks before releasing the set to the customer:

1. Check the area of your repair for unsoldered or poorly-soldered connections. Check the entire board surface for solder splashes and bridges.
2. Check the interboard wiring to ensure that no wires are "pinched" or contact high-wattage resistors.
3. Look for unauthorized replacement parts, particularly transistors, that were installed during a previous repair. Point them out to the customer and recommend their replacement.
4. Look for parts which, through functioning, show obvious signs of deterioration. Point them out to the customer and recommend their replacement.
5. Check the B+ voltage to see it is at the values specified.
6. Flexible Circuit Board Repairing
  - Keep the temperature of the soldering iron around 270°C during repairing.
  - Do not touch the soldering iron on the same conductor of the circuit board (within 3 times).
  - Be careful not to apply force on the conductor when soldering or unsoldering.

## TABLE OF CONTENTS

<u>Section</u>	<u>Title</u>	<u>Page</u>	<u>Section</u>	<u>Title</u>	<u>Page</u>
SERVICE NOTE .....		4	5.	INTERFACE, IC PIN FUNCTION DESCRIPTION	
1.	GENERAL		5-1.	System Control-Video/RP Block Interface (MA-401 BOARD IC162) .....	5-1
	Getting Started .....	1-1	5-2.	System Control-Servo Peripheral Circuit Interface (MA-401 BOARD IC162) .....	5-1
	Basic Operations .....	1-10	5-3.	System Control-Mechanism Block Interface (MA-401 BOARD IC162) .....	5-2
	Additional Operations .....	1-15	5-4.	System Control-System Control Peripheral Circuit Interface (MA-401 BOARD IC162) .....	5-2
2.	DISASSEMBLY		5-5.	System Control-Audio Block Interface (MA-401 BOARD IC162) .....	5-2
2-1.	Upper Case Removal .....	2-1	5-6.	Servo/System Control Microprocessor Pin Functions (MA-401 BOARD IC162) .....	5-3
2-2.	Front Panel Section Removal .....	2-1	5-7.	Mode Control Pin Functions (MA-401 BOARD IC420) .....	5-5
2-3.	Power Block (ETXNY272E2D) Removal .....	2-1	6.	ERROR CODES .....	6-1
2-4.	Rear Panel Removal .....	2-1	7.	ADJUSTMENTS	
2-5.	Mechanism Deck Removal .....	2-2	7-1.	Mechanical Adjustments .....	7-1
2-6.	MA-401 Board Removal .....	2-2	7-2.	Electrical Adjustments .....	7-1
2-7.	Internal Views .....	2-3	2-1.	Preparation Before Adjustments .....	7-1
2-8.	Circuit Boards Location .....	2-4	2-1-1.	Equipment Required .....	7-1
3.	BLOCK DIAGRAMS		2-1-2.	Equipment Connection .....	7-1
3-1.	Overall Block Diagram .....	3-1	2-1-3.	Set-up of Adjustment .....	7-1
3-2.	Video Block Diagram .....	3-3	2-1-4.	Alignment Tapes .....	7-1
3-3.	Servo/System Control Block Diagram .....	3-5	2-1-5.	I/O Level and Impedance .....	7-2
3-4.	Audio/Tuner Block Diagram .....	3-7	2-1-6.	Adjustment Sequence .....	7-2
3-5.	Power Block Diagram .....	3-9	2-2.	Power Supply Check .....	7-2
4.	PRINTED WIRING BOARDS AND SCHEMATIC DIAGRAMS		2-2-1.	Output Voltage Check .....	7-2
4-1.	Frame Schematic Diagram .....	4-3	2-3.	Servo System Check .....	7-3
4-2.	Printed Wiring Boards and Schematic Diagrams .....	4-5	2-3-1.	RF Switching Position Adjustment .....	7-3
	MA-401 Printed Wiring Board .....	4-5	2-4.	Audio System Adjustments .....	7-3
	MA-401 (Head Amp) Schematic Diagram .....	4-9	2-4-1.	Normal Audio System Adjustment .....	7-3
	MA-401 (Video, Audio) Schematic Diagram .....	4-11	2-4-2.	ACE Head Adjustment .....	7-3
	MA-401 (SECAM) Schematic Diagram .....	4-15	2-4-3.	E-E Output Level Check .....	7-3
	MA-401 (Servo/System Control) Schematic Diagram .....	4-17	2-4-4.	Frequency Response Check .....	7-3
	MA-401 (I/O) Schematic Diagram .....	4-21	2-5.	Adjusting Parts Location Diagram .....	7-4
	MA-401 (Tuner) Schematic Diagram .....	4-23	8.	REPAIR PARTS LIST	
	MA-401 (Mode Control) Schematic Diagram .....	4-25	8-1.	Exploded Views .....	8-1
	MA-401 (Power Supply) Schematic Diagram .....	4-27	8-1-1.	Front Panel and Cabinet Assemblies .....	8-1
	KK-26 Schematic Diagram .....	4-29	8-1-2.	Chassis Assembly .....	8-2
	KK-26 Printed Wiring Board .....	4-29	8-1-3.	Mechanism Chassis Assembly (1) .....	8-3
	ETXNY272E2D Printed Wiring Board .....	4-30	8-1-4.	Mechanism Chassis Assembly (2) .....	8-4
	ETXNY272E2D Schematic Diagram .....	4-31	8-1-5.	Mechanism Chassis Assembly (3) .....	8-5
			8-2.	Electrical Parts List .....	8-6

# SERVICE NOTE

## 1. DISASSEMBLY

• This set can be disassembled in the order shown below.

**Note:** Pages in   indicated pages in the SERVICE MANUAL.

Pages in   indicated pages in the VHS MECHANICAL ADJUSTMENT MANUAL VI.

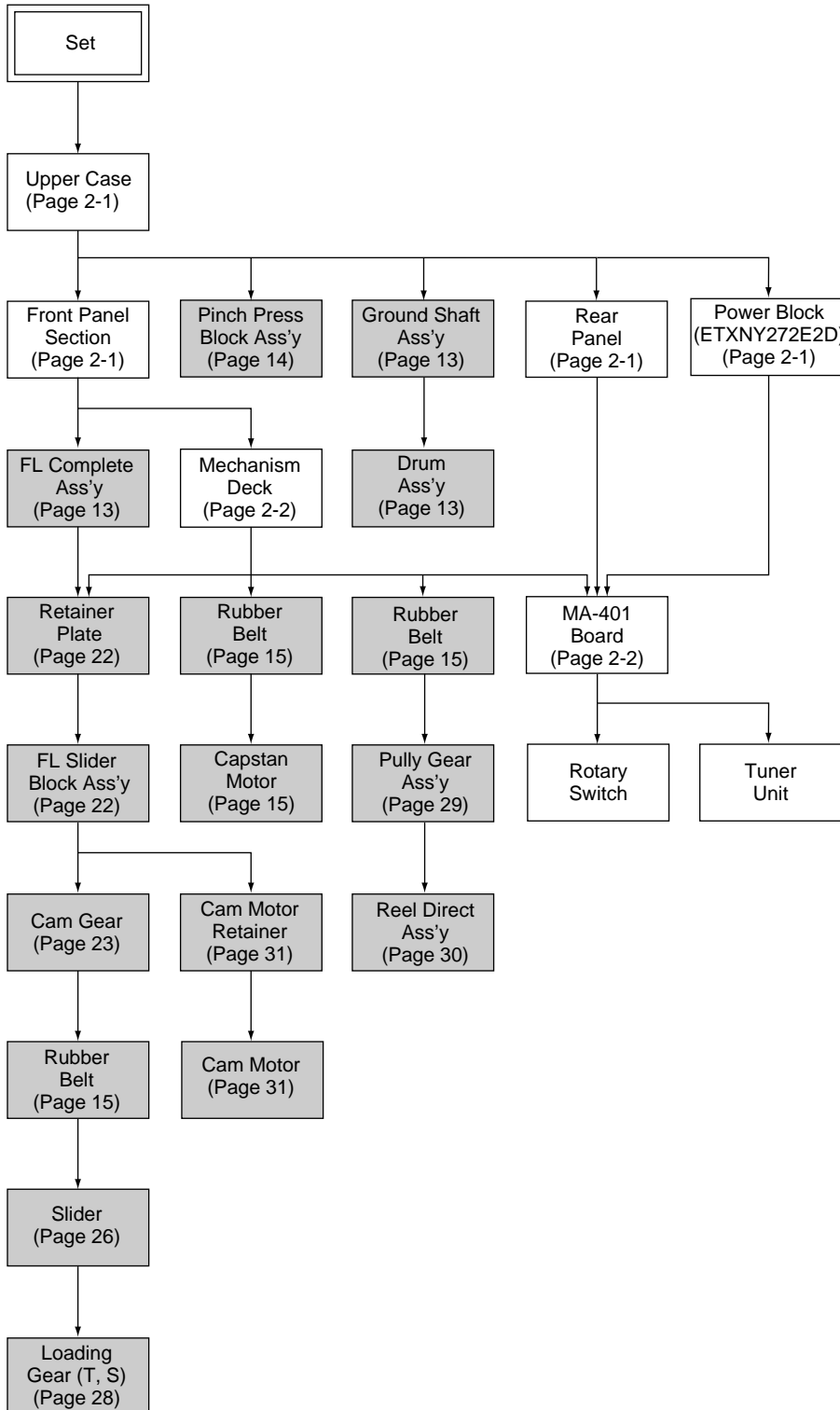

# SECTION 1 GENERAL

This section is extracted from SLV-SE410K/SE510K instruction manual. (3-065-673-11)

Getting Started

## Index to parts and controls

Refer to the pages indicated in parentheses ( ) for details.

### Front panel

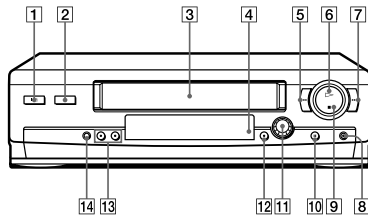

- 1 I/⏻ (on/standby) switch (17)
- 2 ⏏ (eject) button (42)
- 3 Tape compartment
- 4 Remote sensor (10)
- 5 ◀◀ (rewind) button (42) (60)
- 6 ▷ (play) button (42) (60)
- 7 ▶▶ (fast-forward) button (42) (60)
- 8 ● REC (record) button (44) (61) (75)
- 9 ■ (stop) button (42) (75)
- 10 || (pause) button (42) (75)
- 11 ⌚ DIAL TIMER (48)
- 12 SYNCHRO REC (Synchronized Recording) button\* (63)
- 13 PROGRAM +/- buttons (20) (60) (69)
- 14 AUTO SET UP/ RF (Radio Frequency) CHANNEL button (17) (20)

\* SLV-SE510K only

### Display window

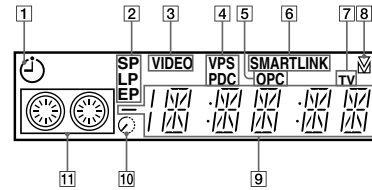

- 1 Timer indicator (50) (54) (58)
- 2 Tape speed indicators (44)
- 3 VIDEO indicator (14) (45)
- 4 VPS (Video Programme System)/ PDC (Programme Delivery Control) indicator\* (55)
- 5 OPC (Optimum Picture Control) indicator (69)
- 6 SMARTLINK indicator\* (15)
- 7 TV indicator\* (46)
- 8 Tracking indicator (69)
- 9 Time counter/clock/line/programme position indicator (42) (44) (75)
- 10 Remaining time indicator (45)
- 11 Tape/recording indicator (44)

\* SLV-SE510K only

Getting Started

### Rear panel

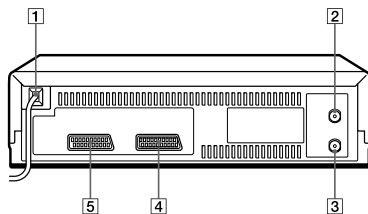

- 1 Mains lead (13) (14)
- 2 AERIAL IN ANTENNE ENTREE connector (13) (14)
- 3 AERIAL OUT ANTENNE SORTIE connector (13) (14)
- 4 DECODER/↔ LINE-2 IN DECODEUR/↔ ENTREE LIGNE-2 connector (16) (37) (62) (74)
- 5 ↔ LINE-1 (TV) ↔ LIGNE-1 (TV) connector (14) (37)

### Remote commander

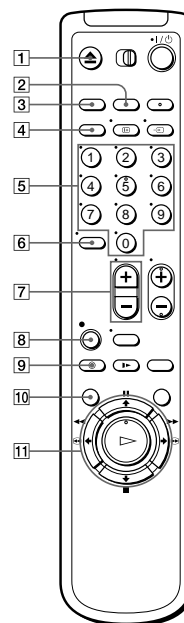

- 1 ▲ EJECT button (42)
- 2 COUNTER/REMAIN button (45)
- 3 CLEAR button (42) (53) (64)
- 4 SP (Standard Play)/LP (Long Play) button (44)
- 5 Programme number buttons (11) (45)
- 6 +/- (ten's digit) button (11) (45)
- 7 ▲ (volume) +/- buttons (for TV) (11)
- 8 ● REC (record) button (44) (61)
- 9 ⌚ TIMER button (53) (57)
- 10 MENU button (23) (64)
- 11 || PAUSE/↑ button (23) (42)  
■ STOP/↓ button (23) (42)  
◀◀ REW (rewind)/◀ button (42) (60)  
▶▶ FF (fast-forward)/▶ button (42) (60)  
▷ PLAY/OK button (23) (42)

Getting Started

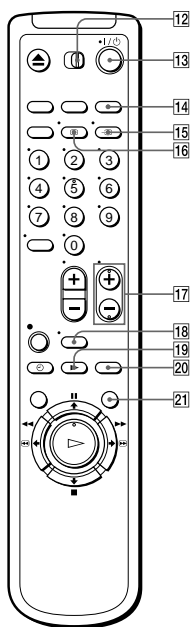

- 12 [TV / VIDEO] remote control switch (10)
- 13 I/⏻ (on/standby) switch (11) (54)
- 14 INPUT SELECT button (45) (58) (75)
- 15 TV/VIDEO button (11) (14) (45)
- 16 [DISP] DISPLAY button (45)
- 17 PROG (programme) +/- buttons (11) (29) (44)
- 18 WIDE button (for TV) (11)
- 19 ▶ SLOW button (60)
- 20 x2 button (60)
- 21 SMART SEARCH button (66)

## Step 1 : Unpacking

Check that you have received the following items with the VCR:

- Remote commander
- Aerial cable

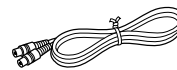
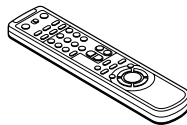

- R6 (size AA) batteries

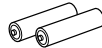

### Check your model name

The instructions in this manual are for the 2 models: SLV-SE410K and SE510K. Check your model number by looking at the rear panel of your VCR. SLV-SE510K is the model used for illustration purposes. Any difference in operation is clearly indicated in the text, for example, "SLV-SE410K only."

## Step 2 : Setting up the remote commander

### Inserting the batteries

Insert two R6 (size AA) batteries by matching the + and - on the batteries to the diagram inside the battery compartment.

Insert the negative (-) end first, then push in and down until the positive (+) end clicks into position.

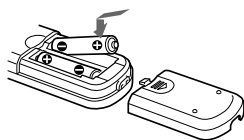

### Using the remote commander

You can use this remote commander to operate this VCR and a Sony TV. Buttons on the remote commander marked with a dot (•) can be used to operate your Sony TV. If the TV does not have the  symbol near the remote sensor, this remote commander will not operate the TV.

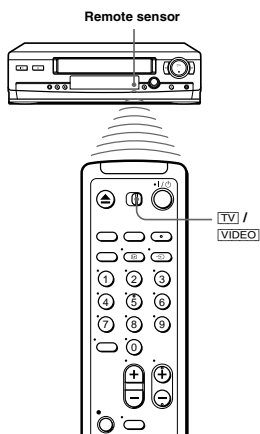

To operate	Set [TV / VIDEO] to
the VCR	[VIDEO] and point at the remote sensor at the VCR
a Sony TV	[TV] and point at the remote sensor at the TV

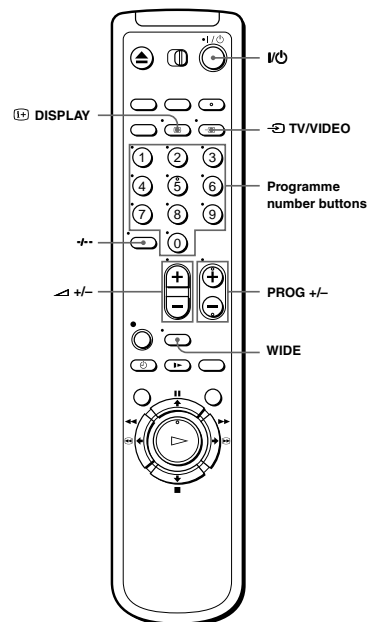

### TV control buttons

To	Press
Set the TV to standby mode	I/⏻
Select an input source: aerial in or line in	[TV/VIDEO]
Select the TV's programme position	Programme number buttons, +/-, PROG +/-
Adjust the volume of the TV	◀ +/-
Call up the on-screen display	[DISP]
Switch to/from wide mode of a Sony wide TV	WIDE

continued

**Notes**

- With normal use, the batteries should last about three to six months.
- If you do not use the remote commander for an extended period of time, remove the batteries to avoid possible damage from battery leakage.
- Do not use a new battery together with an old one.
- Do not use different types of batteries together.
- Some buttons may not work with certain Sony TVs.

**Step 3 : Connecting the VCR**

If your TV has a Scart (EURO-AV) connector, see page 14.

**If your TV does not have a Scart (EURO-AV) connector**

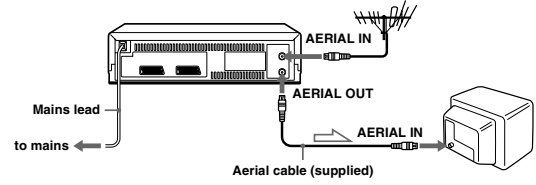

➤ : Signal flow

- 1 Disconnect the aerial cable from your TV and connect it to AERIAL IN on the rear panel of the VCR.
- 2 Connect AERIAL OUT of the VCR and the aerial input of your TV using the supplied aerial cable.
- 3 Connect the mains lead to the mains.

**Note**

- When you connect the VCR and your TV only with an aerial cable, you have to tune your TV to the VCR (see page 17).

**If your TV has a Scart (EURO-AV) connector**

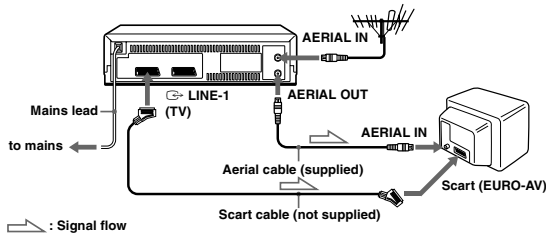

➤ : Signal flow

- 1 Disconnect the aerial cable from your TV and connect it to AERIAL IN on the rear panel of the VCR.
- 2 Connect AERIAL OUT of the VCR and the aerial input of your TV using the supplied aerial cable.
- 3 Connect LINE-1 (TV) on the VCR and the Scart (EURO-AV) connector on the TV with the optional Scart cable. This connection improves picture and sound quality. Whenever you want to watch the VCR picture, press  $\text{TV/VIDEO}$  to display the VIDEO indicator in the display window.
- 4 Connect the mains lead to the mains.

**Note**

- If the TV is connected to the LINE-1 (TV) connector, setting the RF channel to OFF is recommended. In the OFF position, only the signal from the aerial is output through the AERIAL OUT connector (see page 19).

**About the SMARTLINK features (SLV-SE510K only)**

If the connected TV complies with SMARTLINK, MEGALOGIC<sup>®1</sup>, EASYLINK<sup>®2</sup>, Q-Link<sup>®3</sup>, EURO VIEW LINK<sup>®4</sup>, or T-V LINK<sup>®5</sup>, this VCR automatically runs the SMARTLINK function after you complete the steps on the previous page (the SMARTLINK indicator appears in the VCR's display window when you turn on the TV). You can enjoy the following SMARTLINK features.



- Preset Download  
You can download your TV tuner preset data to this VCR and tune the VCR according to that data in Auto Set Up. This greatly simplifies the Auto Set Up procedure. Be careful not to disconnect the cables or exit the Auto Set Up function during the procedure. See "Setting up the VCR with the Auto Set Up function" on page 20.
- TV Direct Rec  
You can easily record what you are watching on the TV. For details, see "Recording what you are watching on the TV (TV Direct Rec) (SLV-SE510K only)" on page 46.
- One Touch Play  
With One Touch Play, you can start playback automatically without turning on the TV. For details, see "Starting playback automatically with one button (One Touch Play) (SLV-SE510K only)" on page 43.
- One Touch Menu  
You can turn on the VCR and TV, set the TV to the video channel, and display the VCR's on-screen display automatically by pressing MENU on the remote commander.
- One Touch Timer  
You can turn on the VCR and TV, set the TV to the video channel, and display the timer recording menu (the TIMER METHOD menu, the TIMER menu, or the SHOWVIEW menu) automatically by pressing  $\text{TIMER}$  on the remote commander. You can set which timer recording menu is displayed using TIMER OPTIONS in the OPTIONS-2 menu (see page 73).
- Automatic Power Off  
You can have the VCR turn off automatically, if the VCR is not used after you turn off the TV.

<sup>®1</sup> "MEGALOGIC" is a registered trademark of Grundig Corporation.  
<sup>®2</sup> "EASYLINK" is a trademark of Philips Corporation.  
<sup>®3</sup> "Q-Link" is a trademark of Panasonic Corporation.  
<sup>®4</sup> "EURO VIEW LINK" is a trademark of Toshiba Corporation.  
<sup>®5</sup> "T-V LINK" is a trademark of JVC Corporation.

**Note**

- Not all TVs respond to the functions above.

## Additional connection

### To a satellite or digital tuner with Line Through

Using the Line Through function, you can watch programmes from a satellite or digital tuner connected to this VCR on the TV even when the VCR is turned off. When you turn on the satellite or digital tuner, this VCR automatically sends the signal from the satellite or digital tuner to the TV without turning itself on.

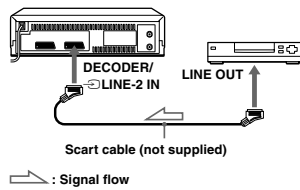

- 1 Connect the satellite or digital tuner to the DECODER/LINE-2 IN connector as shown above.
- 2 Set DECODER/LINE2 to LINE2 in the OPTIONS-2 menu.
- 3 Set POWER SAVE to OFF in the OPTIONS-2 menu.
- 4 Turn off the VCR.  
To watch a programme, turn on the satellite or digital tuner and the TV.

#### Note

- You cannot watch programmes on the TV while recording unless you are recording a satellite or digital programme.

## Step 4 : Tuning your TV to the VCR

If your TV has a Scart (EURO-AV) connector, see page 19.

### If your TV does not have a Scart (EURO-AV) connector

Follow the steps below so that your TV will properly receive the video signals from your VCR.

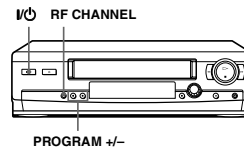

- 1 Press I/O (on/standby) to turn on the VCR.
- 2 AUTO SET UP Press RF CHANNEL on the VCR lightly.  
The factory-preset RF channel appears in the display window.  
The VCR signal is output through this channel to the TV.
- 3 Turn on your TV and select a programme position for the VCR picture.  
This programme position will now be referred to as the video channel.
- 4 AUTO SET UP Press RF CHANNEL.  
The TV system appears in the display window.

*continued*

Tuning your TV to the VCR | 17

16 | Connecting the VCR

- 5 Press PROGRAM +/- (repeatedly) to select the appropriate TV system for your area. Select "G" for the B/G TV system, or "K" for the D/K TV system.
- 6 Tune the TV to the same channel shown in the VCR display window so that the picture on the right appears clearly on the TV screen.  
  
Refer to your TV manual for TV tuning instructions.  
If you select the wrong TV system in step 5, the picture on the right may not appear. Select the appropriate TV system and tune the TV again.  
If the picture does not appear clearly, see "To obtain a clear picture from the VCR" below.
- 7 AUTO SET UP Press RF CHANNEL.  
You have now tuned your TV to the VCR. Whenever you want to play a tape, set the TV to the video channel.

#### To check to see if the TV tuning is correct

Set the TV to the video channel and press PROGRAM +/- on the VCR. If the TV screen changes to a different programme each time you press PROGRAM +/-, the TV tuning is correct.

#### To obtain a clear picture from the VCR

If the screen does not appear clearly in step 6 above, go to step 7 to finish this procedure once. Then start again from step 2. After pressing RF CHANNEL in step 2, press PROGRAM +/- while the RF channel is displayed, so that another RF channel appears. Then tune the TV to the new RF channel so that a clear picture appears.

#### Note

- If you set the wrong TV system, you may have no sound or sound may be distorted.

### If your TV has a Scart (EURO-AV) connector

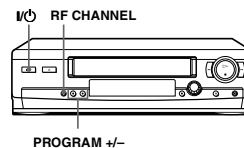

- 1 Press I/O (on/standby) to turn on the VCR.
- 2 AUTO SET UP Press RF CHANNEL on the VCR lightly.  
The factory-preset RF channel appears in the display window.  
The VCR signal is output through this channel to the TV.
- 3 Press PROGRAM +/- to set the RF channel to OFF, and press RF CHANNEL again.  
  
 AUTO SET UP RF channel set up is complete.

18 | Tuning your TV to the VCR

Tuning your TV to the VCR | 19



## Step 5 : Setting up the VCR with the Auto Set Up function

Before using the VCR for the first time, set up the VCR using the Auto Set Up function. With this function, you can set the language for the on-screen display, TV channels, guide channels for the ShowView system\*, and VCR clock\* automatically.

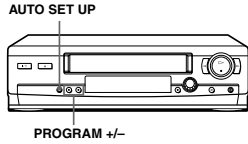

- 1** **AUTO SET UP** Hold down AUTO SET UP on the VCR for more than three seconds. The VCR automatically turns on, and the country abbreviation appears in the display window.
- 2** **- PROGRAM +** Press PROGRAM +/- to select the abbreviation of your country from the table on page 21. For some countries, there is a selection of languages to choose from. If your country does not appear, select ELSE.

- 3** **AUTO SET UP** Press AUTO SET UP lightly. The VCR starts searching for all of the receivable channels and presets them according to the TV system you selected in "Tuning your TV to the VCR" on page 17. If you want to change the order of the channels or disable unwanted programme positions, see "Changing/disabling programme positions" on page 32.



If you use the SMARTLINK connection\*, the Preset Download function starts and the SMARTLINK indicator flashes in the display window during download.

For SLV-SE510K:

After the search or download is complete, the current time appears in the display window for any stations that transmit a time signal.

For SLV-SE410K:

When no more receivable channels can be found, presetting stops and "SET UP" disappears from the display window.

The abbreviations of the countries and languages are as follows:

Abbreviation	Country	Language
CZ	Czecho	Czech
HUN	Hungary	Hungarian
PL	Poland	Polish
SK	Slovakia	Slovak
TR	Turkey	Turkish
RUS	Russia	Russian
ELSE	Other countries	English

To cancel the Auto Set Up function

Press AUTO SET UP.

**Tip**

- If you want to change the language for the on-screen display from the one preset in the Auto Set Up function, see page 27.

### Notes

- If you stop the Auto Set Up function during step 3, you must repeat set up from step 1.
- Whenever you operate the Auto Set Up function, some of the settings (ShowView\*, timer, etc.) will be reset. If this happens, you have to set them again.

\* SLV-SE510K only

## Step 6 : Setting the clock

You must set the time and date on the VCR to use the timer features properly.

The Auto Clock Set function (SLV-SE510K only) works only if a station in your area is broadcasting a time signal. If the Auto Set Up function did not set the clock correctly for your local area, try another station for the Auto Clock Set function.

Setting the clock manually

Before you start...

- Turn on the VCR and the TV.
- Set the TV to the video channel.
- Refer to "Index to parts and controls" for button locations.

- 1** **MENU** Press MENU, then press  $\uparrow/\downarrow$  to highlight SETTINGS and press OK.
- 2** **CLOCK** Press  $\uparrow/\downarrow$  to highlight CLOCK, then press OK. For SLV-SE410K, only the clock setting menu appears. Skip the next step and go to step 4.
- 3** **MANUAL ADJUST** Press  $\uparrow/\downarrow$  to highlight MANUAL ADJUST, then press OK.

**4**  Press **↑/↓** to set the day.

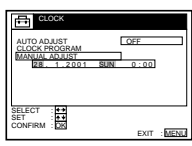

**5**  Press **→** to highlight the month and set the month pressing **↑/↓**.

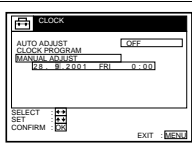

**6**  Set the year, hour, and minutes in sequence, pressing **→** to highlight the item to be set, and press **↑/↓** to select the digits. The day of the week is set automatically.

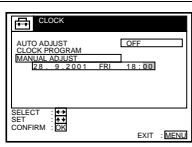

**7**  Press **OK** to start the clock.

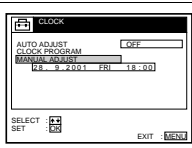

**8**  Press **MENU** to exit the menu.

- Tips**
- To change the digits while setting, press **←** to return to the item to be changed, and select the digits by pressing **↑/↓**.
  - If you want to return to the previous menu, highlight **RETURN** and press **OK**.
- Note**
- The menu disappears automatically if you don't proceed for more than a few minutes.

### Changing the station for the Auto Clock Set function (SLV-SE510K only)

**Before you start...**

- Turn on the VCR and the TV.
- Set the TV to the video channel.
- Refer to "Index to parts and controls" for button locations.

**1**  Press **MENU**, then press **↑/↓** to highlight **SETTINGS** and press **OK**.

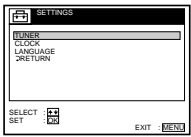

**2**  Press **↑/↓** to highlight **CLOCK**, then press **OK**. **AUTO ADJUST** is highlighted.

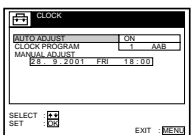

**3**  Press **OK**.

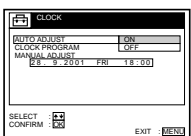

**4**  Press **↑/↓** to highlight **ON**, then press **OK**.

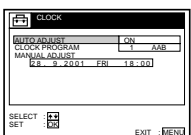

**5**  Press **↓** to highlight **CLOCK PROGRAM**, then press **OK**.

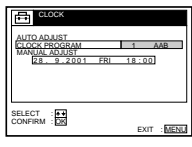

**6**  Press **↑/↓** repeatedly until the programme position of the station that carries a time signal appears. If the VCR does not receive a time signal from any station, **AUTO ADJUST** returns to **OFF** automatically.

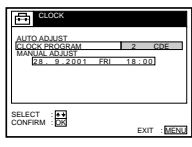

**7**  Press **MENU** to exit the menu.

- Tips**
- If you set **AUTO ADJUST** to **ON**, the Auto Clock Set function is activated whenever the VCR is turned off. The time is adjusted automatically by making reference to the time signal from the station whose programme position is displayed in the "CLOCK PROGRAM" row. If you do not need the Auto Clock Set, select **OFF**.
  - If you want to return to the previous menu, highlight **RETURN** and press **OK**.
- Note**
- The menu disappears automatically if you don't proceed for more than a few minutes.

### Selecting a language

You can change the on-screen display language from the one you selected with the Auto Set Up function.

**Before you start...**

- Turn on the VCR and the TV.
- Set the TV to the video channel.
- Refer to "Index to parts and controls" for button locations.

**1**  Press **MENU**, then press **↑/↓** to highlight **SETTINGS** and press **OK**.

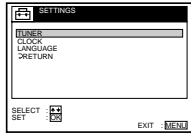

**2**  Press **↑/↓** to highlight **LANGUAGE**, then press **OK**.



**3**  Press **↑/↓** to highlight the desired language, then press **OK**.

**4**  Press **MENU** to exit the menu.

- Tip**
- If you want to return to the previous menu, highlight **RETURN** and press **OK**.
- Note**
- The menu disappears automatically if you don't proceed for more than a few minutes.

## Presetting channels

If some channels could not be preset using the Auto Set Up function, you can preset them manually.

### Before you start...

- Turn on the VCR and the TV.
- Set the TV to the video channel.
- Refer to "Index to parts and controls" for button locations.

**1**  Press MENU, then press  $\uparrow/\downarrow$  to highlight SETTINGS and press OK.

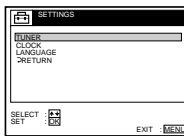

**2**  Press  $\uparrow/\downarrow$  to highlight TUNER, then press OK.

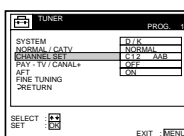

**3**  Press  $\uparrow/\downarrow$  to highlight NORMAL/CATV, then press OK.

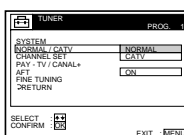

**4**  Press  $\uparrow/\downarrow$  to highlight NORMAL, then press OK.  
To preset CATV (Cable Television) channels, select CATV.

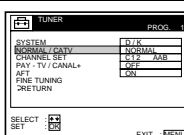

**7**  Press  $\uparrow/\downarrow$  repeatedly until the channel you want is displayed.

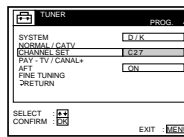



The channels appear in the following order:

B/G TV system		D/K TV system	
Channel number in the CHANNEL SET field	Receivable Channel	Channel number in the CHANNEL SET field	Receivable Channel
C02	E2	C02	R1
C03	E3	C05	R6
C04	E4	C06	R7
C05	E5	C12	R12
C06	E6	C13	R2
C07	E7	C14	R3
C08	E8	C15	R4
C09	E9	C16	R5
C10	E10	C17	R8
C11	E11	C18	R9
C12	E12	C19	R10
C21-C69	E21-E69	C20	R11
S01-S41	S1-S41	C21-C69	R21-R69
S42-S46	S01-S05		

If you know the number of the channel you want, press the programme number buttons. For example, for channel 5, first press "0" and then press "5."

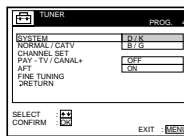
**8**  If the TV sound is distorted or noisy, press  $\uparrow/\downarrow$  to highlight SYSTEM and press OK. Then press  $\uparrow/\downarrow$  to select B/G or D/K so that you get better sound.



**5**  Press PROG +/- to select the programme position.

Selected programme position

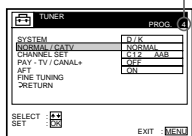

**6**  Press  $\uparrow/\downarrow$  to highlight CHANNEL SET, then press OK.

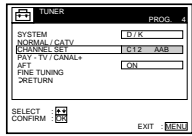

**9** To preset another programme position, repeat steps 5 through 7.

**10**  Press MENU to exit the menu.

### If the picture is not clear

Normally, the Auto Fine Tuning (AFT) function automatically tunes in channels clearly. However, if the picture is not clear, you may also use the manual tuning function.

- 1 Press PROG +/- or the programme number buttons to select the programme position for which you cannot obtain a clear picture.
- 2 Press MENU, then select SETTINGS and press OK.
- 3 Select TUNER, then press OK.
- 4 Select FINE TUNING, then press OK.

The fine tuning meter appears.

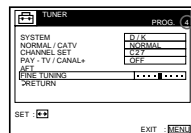

Selected programme position

- 5 Press  $\leftarrow/\rightarrow$  to get a clearer picture, then press MENU to exit the menu. Note that the AFT (Auto Fine Tuning) setting switches to OFF.

### Tip

- If you want to return to the previous menu, highlight RETURN and press OK.

### Notes

- The menu disappears automatically if you don't proceed for more than a few minutes.
- When adjusting FINE TUNING, the menu may become difficult to read due to interference from the picture being received.

## Changing/disabling programme positions





After setting the channels, you can change the programme positions as you like. If any programme positions are unused or contain unwanted channels, you can disable them.



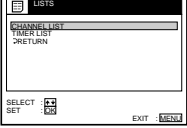

You can also change the station names (SLV-SE510K only). If the station names are not displayed, you can enter them manually.

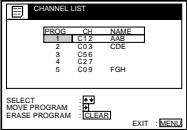
### Changing programme positions

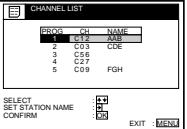
#### Before you start...

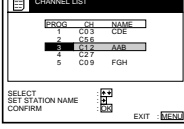
- Turn on the VCR and the TV.
- Set the TV to the video channel.
- Refer to "Index to parts and controls" for button locations.

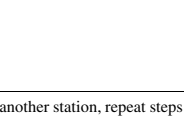
-  Press MENU, then press **↑/↓** to highlight LISTS and press OK.
 
-  Press **↑/↓** to highlight CHANNEL LIST, then press OK.
 
-  Press **↑/↓** to highlight the row which you want to change the programme position, then press **→**. To display other pages for programme positions 6 to 60, press **↑/↓** repeatedly.
 

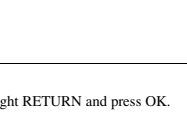
-  Press **↑/↓** until the selected channel row moves to the desired programme position. The selected channel is inserted at the new programme position and the intermediate channels are displaced to fill the gap.
 
-  Press OK to confirm the setting.
 
- To change the programme position of another station, repeat steps 3 through 5.
-  Press MENU to exit the menu.
 

- Tip**
- If you want to return to the previous menu, highlight RETURN and press OK.
- Note**
- The menu disappears automatically if you don't proceed for more than a few minutes.





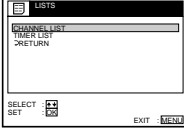

### Disabling unwanted programme positions

After presetting channels, you can disable unused programme positions. The disabled positions will be skipped later when you press the PROG +/- buttons.

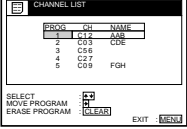
#### Before you start...

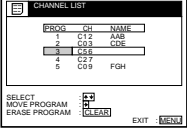
- Turn on the VCR and the TV.
- Set the TV to the video channel.
- Refer to "Index to parts and controls" for button locations.

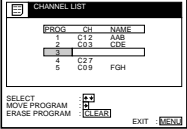
-  Press MENU, then press **↑/↓** to highlight LISTS, and press OK.
 

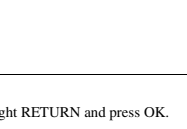
-  Press **↑/↓** to highlight CHANNEL LIST, then press OK.
 
-  Press **↑/↓** to highlight the row which you want to disable.
 
-  Press CLEAR. The selected row will be cleared as shown on the right.
 
- Repeat steps 3 and 4 for any other programme positions you want to disable.
-  Press MENU to exit the menu.
 







- Tip**
- If you want to return to the previous menu, highlight RETURN and press OK.
- Notes**
- The menu disappears automatically if you don't proceed for more than a few minutes.
  - Be sure to select the programme position you want to disable correctly. If you disable a programme position by mistake, you need to reset that channel manually.

### Changing the station names (SLV-SE510K only)

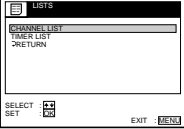
You can change or enter the station names (up to 5 characters). The VCR must receive channel information (for instance, SMARTLINK information) for station names to appear automatically.

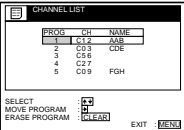
#### Before you start...

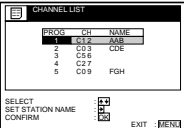
- Turn on the VCR and the TV.
- Set the TV to the video channel.
- Refer to "Index to parts and controls" for button locations.

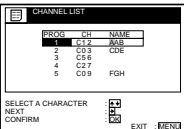
-  Press MENU, then press **↑/↓** to highlight LISTS and press OK.
 
-  Press **↑/↓** to highlight CHANNEL LIST, then press OK.
 
-  Press **↑/↓** to highlight the row which you want to change or enter the station name, then press **→**. To display other pages for programme positions 6 to 60, press **↑/↓** repeatedly.
 
-  Press **→**.
 

**5** Enter the station name.

1 Press  $\uparrow/\downarrow$  to select a character. Each time you press  $\uparrow$ , the character changes as shown below.

A  $\rightarrow$  B  $\rightarrow$  ...  $\rightarrow$  Z  $\rightarrow$  a  $\rightarrow$  b  $\rightarrow$  ...  $\rightarrow$  z  $\rightarrow$  0  $\rightarrow$  1  $\rightarrow$  ...  $\rightarrow$  9  $\rightarrow$  (symbols)  $\rightarrow$  (blank space)  $\rightarrow$  A

2 Press  $\rightarrow$  to set the next character. The next space is highlighted. To correct a character, press  $\leftarrow/\rightarrow$  until the character you want to correct is highlighted, then reset it. You can set up to 5 characters for the station name.

**6** Press OK to confirm the new name.

**7** Press MENU to exit the menu.

- Tip**
- If you want to return to the previous menu, highlight RETURN and press OK.
- Notes**
- The menu disappears automatically if you don't proceed for more than a few minutes.
  - If you enter a symbol in step 5, it will appear as a blank space in the display window.

## Setting the Canal Plus decoder

You can watch or record Canal Plus programmes if you connect a decoder (not supplied) to the VCR.

### Connecting a decoder

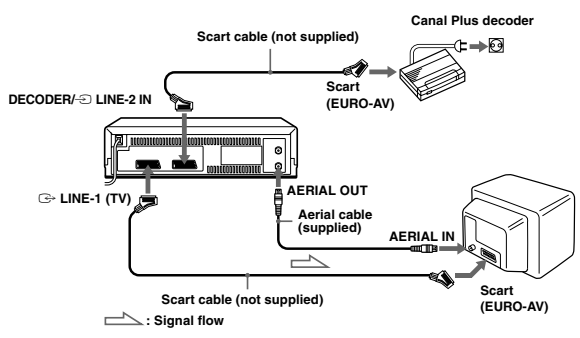

### Setting Canal Plus channels

To watch or record Canal Plus programmes, set your VCR to receive the channels using the on-screen display.

In order to set the channels correctly, be sure to follow all of the steps below.

#### Before you start...

- Turn on the VCR, the TV, and the decoder.
- Set the TV to the video channel.
- Refer to "Index to parts and controls" for button locations.

**1** Press MENU, then press  $\uparrow/\downarrow$  to highlight OPTIONS and press OK.

**2** Press  $\uparrow/\downarrow$  to highlight OPTIONS-2, then press OK.

**3** Press  $\uparrow/\downarrow$  to highlight DECODER/LINE2, then press OK.

**4** Press  $\uparrow/\downarrow$  to highlight DECODER, then press OK.

**5** Press MENU to exit the menu. The menu disappears from the TV screen.

continued

**6** Press MENU again. Then press  $\uparrow/\downarrow$  to highlight SETTINGS and press OK.





**7** Press  $\uparrow/\downarrow$  to highlight TUNER, then press OK.

**8** Press  $\uparrow/\downarrow$  to highlight NORMAL/CATV, then press OK.

**9** Press  $\uparrow/\downarrow$  to highlight NORMAL, then press OK. To preset CATV (Cable Television) channels, select CATV.

**10** Press PROG +/- to select the desired programme position.

**Selected programme position**

- 11**  Press **↑/↓** to highlight CHANNEL SET, then press OK.
- 12**  Press **↑/↓** to select the Canal Plus channels, then press OK.
- 13**  Press **↑/↓** to highlight PAY-TV/CANAL+, then press OK.
- 14**  Press **↑/↓** to highlight ON, then press OK.
- 15**  If the TV sound is distorted or noisy, press **↑/↓** to highlight SYSTEM and press OK. Then press **↑/↓** to select B/G or D/K so that you get better sound.

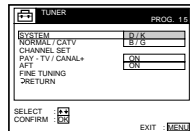
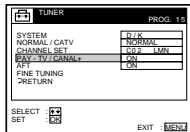
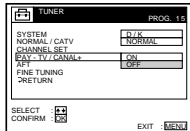
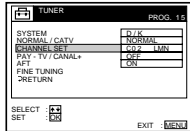
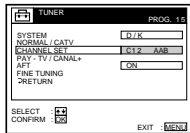

- 16**  Press MENU to exit the menu.

**Tip**

- If you want to return to the previous menu, highlight RETURN and press OK.

**Notes**

- The menu disappears automatically if you don't proceed for more than a few minutes.
- To superimpose subtitles while watching Canal Plus programmes, make both decoder-VCR and VCR-TV connections using 21-pin Scart cables that are compatible with the RGB signals. You cannot record subtitles on the VCR.
- When you watch Canal Plus programmes through the RFU input of the TV, press **TV/VIDEO** so that the VIDEO indicator appears in the display window.

**Basic Operations****Playing a tape****Before you start...**

- Refer to "Index to parts and controls" for button locations.

- 1** Turn on your TV and set it to the video channel.
- 2** Insert a tape.  
The VCR turns on and starts playing automatically if you insert a tape with its safety tab removed.
- 3**  Press **▷ PLAY**.  
When the tape reaches the end, it will rewind automatically.

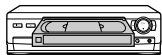
**Additional tasks**

To	Press
Stop play	<b>■ STOP</b>
Pause play	<b>   PAUSE</b>
Resume play after pause	<b>   PAUSE</b> or <b>▷ PLAY</b>
Fast-forward the tape	<b>▶▶ FF</b> during stop
Rewind the tape	<b>◀◀ REW</b> during stop
Eject the tape	<b>▲ EJECT</b>

**To set the colour system**

If the playback picture has no colour, or streaks appear during playback, set COLOUR SYSTEM in the OPTIONS-1 menu to conform to the system that the tape was recorded in (see page 73). (Normally set the option to AUTO.)

**To use the time counter**

Press CLEAR at the point on the tape that you want to find later. The counter in the display window resets to "0:00:00." Search for the point afterwards by referring to the counter.

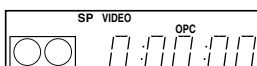

To display the counter on the TV screen, press **DISP** DISPLAY.

**Notes**

- The counter resets to "0:00:00" whenever a tape is reinserted.
- The counter stops counting when it comes to a portion with no recording.
- The time counter does not appear on the TV screen when using an NTSC-recorded tape.
- Depending on your TV, the following may occur while playing an NTSC-recorded tape:
  - The picture becomes black and white.
  - The picture shakes.
  - No picture appears on the TV screen.
  - Black streaks appear horizontally on the TV screen.
  - The colour density increases or decreases.
- While setting the menu on the TV screen, buttons for playback on the remote commander do not function.

**Starting playback automatically with one button (One Touch Play) (SLV-SE510K only)**

If you use the SMARTLINK connection, you can turn on the VCR and the TV, set the TV to the video channel, and start playback automatically with one button.

- 1** Insert a tape.  
The VCR automatically turns on.  
If you insert a tape with its safety tab removed, the TV turns on and switches to the video channel. Playback starts automatically.
- 2** Press **▷ PLAY**.  
The TV turns on and switches to the video channel automatically. Playback starts.

**Tip**

- When there already is a tape in the VCR, the VCR and the TV turn on, the TV is set to the video channel, and playback starts automatically in one sequence when you press **▷ PLAY**.

**Note**

- When you use the One Touch Play function, leave the TV on or in the standby mode.

## Recording TV programmes

### Before you start...

- Refer to "Index to parts and controls" for button locations.

- Turn on your TV and set it to the video channel.  
To record from a decoder, turn it on.
- Insert a tape with its safety tab in place.
- PROG

Press PROG +/- to select the programme position or station name\* you want to record.

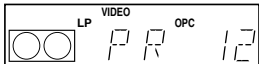

- SP / LP

Press SP/LP to select the tape speed, SP or LP.  
LP (Long Play) provides recording time twice as long as SP. However, SP (Standard Play) produces better picture and audio quality.

- REC

Press ● REC to start recording.  
The recording indicator lights up red in the display window.

Recording indicator



### To stop recording

Press ■ STOP.

### To check the remaining time

Press [DISPLAY]. With the display on, press COUNTER/REMAIN to check the remaining time. Each time you press COUNTER/REMAIN, the time counter and the remaining time appear alternately. The [REMAIN] indicator indicates the remaining time.

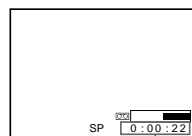

Time counter

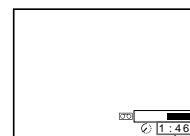

Remaining time

In order to get an accurate remaining time indication, be sure TAPE LENGTH in the OPTIONS-1 menu is set according to the tape type you use (see page 72).

### To watch another TV programme while recording

- Press [TV/VIDEO] to turn off the VIDEO indicator in the display window.
- Select another programme position on the TV.

### To save a recording

To prevent accidental erasure, break off the safety tab as illustrated. To record on the same tape again, cover the tab hole with adhesive tape.



Safety tab

### Tips

- To select a programme position, you can use the programme number buttons on the remote commander. For two-digit numbers, press the -/- (ten's digit) button followed by the programme number buttons.
- If you connect additional equipment to a LINE connector or jack, you can select the input signal using the INPUT SELECT or PROG +/- buttons.
- The [DISPLAY] information appears on the TV screen indicating information about the tape, but the information won't be recorded on the tape.
- If you don't want to watch TV while recording, you can turn off the TV. When using a decoder, make sure to leave it on.

### Notes

- The [DISPLAY] information does not appear during still (pause) mode or slow-motion playback.
- The [DISPLAY] information will not appear while playing an NTSC-recorded tape.
- If a tape has portions recorded in both PAL (MESECAM) and NTSC systems, the time counter reading will not be correct. This discrepancy is due to the difference between the counting cycles of the two video systems.
- You cannot watch a Canal Plus programme while recording another Canal Plus programme.
- When you insert a non-standard commercially available tape, the remaining time may not be correct.
- The remaining time is intended for rough measurement only.
- About 30 seconds after the tape begins playback, the tape remaining time will be displayed.
- The station name\* may not appear if the VCR does not receive station name information signals.

\* SLV-SE510K only

### Recording what you are watching on the TV (TV Direct Rec) (SLV-SE510K only)

If you use the SMARTLINK connection, you can easily record what you are watching on the TV (other than tapes being played on the VCR).

- Insert a tape with its safety tab in place.
- Press ● REC while you are watching a TV programme or external source.  
The VCR automatically turns on, then the TV indicator lights up and the VCR starts recording what you are watching on the TV.

### Tips

- The TV indicator appears in the display window after you press ● REC in some situations such as:
  - when you are watching a source connected to the TV's line input, or
  - when the TV tuner preset data for the programme position is different from the data in the VCR tuner preset.
- If there is a tape with its safety tab in place in the VCR, the VCR automatically turns on and starts recording what you are watching on the TV when you press ● REC.
- You can turn the TV Direct Rec function ON and OFF in the OPTIONS-2 menu (see page 73).

## Recording TV programmes using the Dial Timer

The Dial Timer function allows you to make timer recordings of programmes without turning on your TV. Set the recording timer to record up to eight programmes, including settings made with other timer methods, that will be broadcast within the next month. The recording start time and recording stop time can be set at one minute intervals.

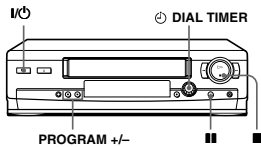

### Before you start...

- Insert a tape with its safety tab in place. Make sure the tape is longer than the total recording time.
- To record from a decoder, turn it on.
- Refer to "Index to parts and controls" for button locations.

- 1 Press DIAL TIMER. "DATE" and "TODAY" appear alternately in the display window. If the date and time are not set, "DAY" will appear. See step 2 in the following section, "To set the clock" to set the date and time.

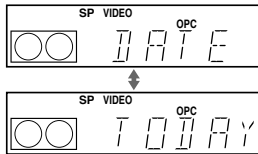

- 2 Turn DIAL TIMER to set the recording date.

- 3 Press DIAL TIMER. "START" and the current time appear alternately in the display window.

- 4 Turn DIAL TIMER to set the recording start time. You can set the recording start time in 15 minute intervals or adjust the time in one minute intervals by pressing the PROGRAM +/- buttons.

- 5 Press DIAL TIMER. "STOP" and the recording stop time appear alternately in the display window.

- 6 Turn DIAL TIMER to set the recording stop time. You can set the recording stop time in 15 minute intervals or adjust the time in one minute intervals by pressing the PROGRAM +/- buttons.

- 7 Press DIAL TIMER. The programme position or station name appears in the display window.

- 8 Turn DIAL TIMER to set the programme position. To record from a decoder or other source connected to one or more of the LINE inputs, turn DIAL TIMER or press INPUT SELECT to display the connected line in the display window.

- 9 Press DIAL TIMER to complete the setting. "OK" appears in the display window for about five seconds. The indicator appears in the display window and the VCR stands by for recording. To record from a decoder or other source, leave the connected equipment switched on.

### To return to the previous step

To return to the previous step, press the PROGRAM + and - buttons on the VCR at the same time during any of the Dial Timer settings.

### To stop recording

To stop the VCR while recording, press STOP.

### To use the VCR after setting the timer

To use the VCR before a recording begins, just press . The indicator turns off and the VCR switches on. Remember to press to reset the VCR to recording standby after using the VCR.

You can also do the following tasks while the VCR is recording:

- Reset the counter (page 42).
- Display tape information on the TV screen (page 45).
- Check the timer settings (page 64).
- Watch another TV programme (page 45).

### To set the clock

- 1 Turn DIAL TIMER so that "CLOCK" appears in the display window.
- 2 Press DIAL TIMER. "DAY" appears in the display window.
- 3 Turn DIAL TIMER to set the day.
- 4 Press DIAL TIMER. "MONTH" appears in the display window.
- 5 Turn and press DIAL TIMER to set the month, and then the year. After you set the year, "CLOCK" appears in the display window again.
- 6 Turn and press DIAL TIMER to set the hour and minute.
- 7 When you have finished setting the time, press DIAL TIMER to start the clock.

### Tips

- To cancel a Dial Timer setting, press (stop) on the VCR while you are making the setting.
- The programme is recorded in the current tape speed mode. To change the tape speed, press SP/LP before you complete the setting in step 9.
- When you are recording a programme in the SP mode and the remaining tape becomes shorter than the recording time, the tape speed is automatically changed to the LP mode. Note that some interference will appear on the picture at the point the tape speed is changed. If you want to keep the same tape speed, set AUTO LONG PLAY to OFF in the OPTIONS-1 menu (page 72).
- To check, change, or cancel the programme setting, see "Checking/changing/cancelling timer settings" (page 64).

### Notes

- If eight programmes have already been set using the ShowView system\* or the TIMER menu, "FULL" appears in the display window for about five seconds.
- The indicator flashes in the display window when you complete the setting in step 9 with no tape inserted.
- If you set the clock using the Auto Clock Set function\* and AUTO ADJUST is set to ON, the clock will adjust itself to the incoming time signal regardless of adjustments made with the Dial Timer. Be sure you have set the Auto Clock Set correctly.
- The station name\* may not appear if the VCR does not receive station name information signals.

\* SLV-SE510K only



## About the Demonstration Mode

The Dial Timer function has a Demonstration Mode that allows the user, such as a salesperson, to enter more than eight examples of timer settings when demonstrating the use of the Dial Timer. It cancels the FULL notice which appears if eight programmes have already been set. Do not use the Demonstration Mode for making timer recordings. Doing so may cause the settings to be inaccurate.

### To activate the Demonstration Mode

Press **II** (pause) on the VCR while turning the **⊖** DIAL TIMER. "DEMO" appears in the display window for a few seconds.

### To cancel the Demonstration Mode

Turn the power off and unplug the mains lead. Although the Demonstration Mode is cancelled, the timer settings entered while using the Demonstration Mode will remain. Be sure to manually cancel the timer settings before you use the Dial Timer or any other timer method after reconnecting the mains lead (see page 64).

## Recording TV programmes using the ShowView system (SLV-SE510K only)

The ShowView system is the feature that simplifies programming the VCR to make timer recordings. Just enter the ShowView number listed in the TV programme guide. The date, times, and programme position of that programme are set automatically. You can preset a total of eight programmes, including settings made with other timer methods.

### Before you start...

- Check that the VCR clock is set to the correct time and date.
- Insert a tape with its safety tab in place. Make sure the tape is longer than the total recording time.
- To record from a decoder, turn it on.
- Turn on your TV and set it to the video channel.
- Set TIMER OPTIONS to SHOWVIEW or VARIABLE in the OPTIONS-2 menu (see page 73).
- Refer to "Index to parts and controls" for button locations.

**1**  Press **⊖** TIMER.

- When you set TIMER OPTIONS to VARIABLE:  
The TIMER METHOD menu appears on the TV screen. Press **↑/↓** to select SHOWVIEW, then press OK.
- When you set TIMER OPTIONS to SHOWVIEW:  
The SHOWVIEW menu appears on the TV screen.

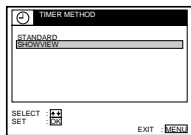
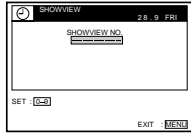
**2**  Press the programme number buttons to enter the ShowView number.  
If you make a mistake, press CLEAR and re-enter the correct number.

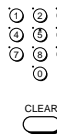

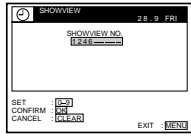
**3**  Press OK.

The date, start and stop times, programme position or station name, tape speed, and VPS/PDC setting appear on the TV screen.

- If "--" appears in the "PROG." (programme) column (this may happen for local broadcasts), you have to set the appropriate programme position manually. Press **↑/↓** to select the desired programme position.

To record from a decoder or other source connected to one or more of the LINE inputs, press INPUT SELECT to display the connected line in the "PROG." position. You will only have to do this operation once for the referred channel. The VCR will then store your setting.

If the information is incorrect, press CLEAR to cancel the setting.

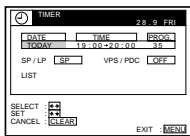



**4**  If you want to change the date, tape speed, and the VPS/PDC setting:

- 1 Press **←/→** to highlight the item you want to change.
- 2 Press **↑/↓** to reset it.

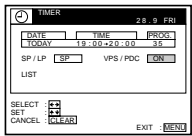
- To record the same programme every day or the same day every week, see "Daily/weekly recording" on page 55.
- To use the VPS/PDC function, set VPS/PDC to ON. For details of the VPS/PDC function, see "Timer recording with VPS/PDC signals" on page 55.



**5**  Press MENU to exit the menu.

**6**  Press **I/O** to turn off the VCR.

The **⊖** indicator appears in the display window and the VCR stands by for recording.

To record from a decoder or other source, leave the connected equipment switched on.

### To stop recording

To stop the VCR while recording, press **■** STOP.

continued

### Daily/weekly recording

In step 4 above, press **↓** to select the recording pattern. Each time you press **↓**, the indication changes as shown below. Press **↑** to change the indication in reverse order.

**TODAY** → **SUN-SAT** (Sunday to Saturday) → **MON-SAT** (Monday to Saturday) → **MON-FRI** (Monday to Friday) → **SAT** (every Saturday) ..... → **MON** (every Monday) → **SUN** (every Sunday) → **1 month later** → (dates count down) → **TOMORROW** → **TODAY**

### Timer recording with VPS/PDC signals

Some broadcast systems transmit VPS (Video Programme System) or PDC (Programme Delivery Control) signals with their TV programmes. These signals ensure that your timer recordings are made regardless of broadcast delays, early starts, or broadcast interruptions (when the VPS or PDC indicator in the display window is lit).

To use the VPS/PDC function, set VPS/PDC to ON in step 4 above. You can also use the VPS/PDC function for a source connected to one or more of the LINE inputs.

### To record satellite broadcasts

If you connect a satellite tuner and the VCR, you can record satellite programmes.

- 1 Turn on the satellite tuner.
- 2 On the satellite tuner, select the satellite programme for which you want to make a timer setting.
- 3 Follow steps 1 through 6 above.
- 4 Keep the satellite tuner turned on until the VCR finishes recording the satellite programme for which you have made a timer setting.

### To use the VCR after setting the timer

To use the VCR before a recording begins, just press **I/O**. The **⊖** indicator turns off and the VCR switches on. Remember to press **I/O** to reset the VCR to recording standby after using the VCR.

You can also do the following tasks while the VCR is recording:

- Reset the counter (page 42).
- Display tape information on the TV screen (page 45).
- Check the timer settings (page 64).
- Watch another TV programme (page 45).

**Tips**

- To set the programme position, you can also use the PROG +/- or programme number buttons.
- To set the programme position with a two digit number, press -/- (ten's digit) button followed by the programme number buttons.
- To set the line input video source, you can also use the PROG +/- buttons.
- To set the tape speed, you can also use the SP/LP button.
- When you are recording a programme in the SP mode and the remaining tape becomes shorter than the recording time, the tape speed is automatically changed to the LP mode. Note that some interference will appear on the picture at the point the tape speed is changed. If you want to keep the same tape speed, set AUTO LONG PLAY to OFF in the OPTIONS-1 menu (page 72).
- To check, change, or cancel the programme setting, press ←/→ to choose LIST, then press OK in step 4. For details, see step 3 in "Checking/changing/cancelling timer settings" (page 64).

**Notes**

- If the VPS/PDC signal is too weak or the broadcasting station failed to transmit VPS/PDC signals, the VCR will start recording at the set time without using the VPS/PDC function.
- The ⊙ indicator flashes in the display window when you press I/⏪ with no tape inserted.
- When you set TIMER OPTIONS to STANDARD in the OPTIONS-2 menu, the SHOWVIEW menu does not appear on the TV screen. Select SHOWVIEW or VARIABLE.
- The VPS/PDC function is automatically set to OFF for the timer recording of a satellite programme.
- The station name may not appear if the VCR does not receive station name information signals.

**Recording TV programmes using the timer**

You can preset a total of eight programmes, including settings made with other timer methods.

**Before you start...**

- Check that the VCR clock is set to the correct time and date.
- Insert a tape with its safety tab in place. Make sure the tape is longer than the total recording time.
- To record from a decoder, turn it on.
- Turn on your TV and set it to the video channel.
- Set TIMER OPTIONS\* to STANDARD or VARIABLE in the OPTIONS-2 menu (see page 73).
- Refer to "Index to parts and controls" for button locations.

**1**

Press ⊙ TIMER.

For SLV-SE410K:  
The TIMER menu appears on the TV screen.

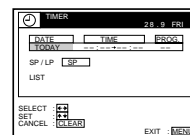

For SLV-SE510K:

- When you set TIMER OPTIONS to VARIABLE:  
The TIMER METHOD menu appears on the TV screen. Press ↑/↓ to select STANDARD, then press OK.

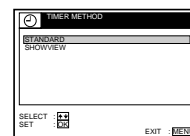

- When you set TIMER OPTIONS to STANDARD:  
The TIMER menu appears on the TV screen.

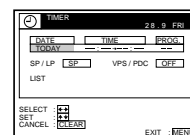

continued

**2**

Set the date, start and stop times, programme position or station name\*, tape speed, and VPS/PDC function\*:

1 Press → to highlight each item in turn.

2 Press ↑/↓ to set each item.

To correct a setting, press ← to return to that setting and reset.

- To record the same programme every day or the same day every week, see "Daily/weekly recording" below.
- To use the VPS/PDC function, set VPS/PDC to ON. For details about the VPS/PDC function, see "Timer recording with VPS/PDC signals" on page 55.
- To record from a decoder or other source connected to one or more of the LINE inputs, press INPUT SELECT to display the connected line in the "PROG." position.

**3**

Press MENU to exit the menu.

**4**

Press I/⏪ to turn off the VCR.

The ⊙ indicator appears in the display window and the VCR stands by for recording.

To record from a decoder or other source, leave the connected equipment switched on.

**To stop recording**

To stop the VCR while recording, press ■ STOP.

**Daily/weekly recording**

In step 2 above, press ↓ to select the recording pattern. Each time you press ↓, the indication changes as shown below. Press ↑ to change the indication in reverse order.

TODAY → SUN-SAT (Sunday to Saturday) → MON-SAT (Monday to Saturday) → MON-FRI (Monday to Friday) → SAT (every Saturday) ..... → MON (every Monday) → SUN (every Sunday) → 1 month later → (dates count down) → TOMORROW → TODAY

**To use the VCR after setting the timer**

To use the VCR before a recording begins, just press I/⏪. The ⊙ indicator turns off and the VCR switches on. Remember to press I/⏪ to reset the VCR to recording standby after using the VCR.

You can also do the following tasks while the VCR is recording:

- Reset the counter (page 42).
- Display tape information on the TV screen (page 45).
- Check the timer settings (page 64).
- Watch another TV programme (page 45).

**Tips**

- To set the programme position, you can also use the PROG +/- or programme number buttons.
- To set the programme position with a two digit number, press -/- (ten's digit) button followed by the programme number buttons.
- To set the line input video source, you can also use the PROG +/- buttons.
- To set the tape speed, you can also use the SP/LP button.
- When you are recording a programme in the SP mode and the remaining tape becomes shorter than the recording time, the tape speed is automatically changed to the LP mode. Note that some interference will appear on the picture at the point the tape speed is changed. If you want to keep the same tape speed, set AUTO LONG PLAY to OFF in the OPTIONS-1 menu (page 72).
- Even if you set TIMER OPTIONS\* to SHOWVIEW in the OPTIONS-2 menu, you can set the timer manually. Press MENU to select TIMER, then go to step 2.
- To check, change, or cancel the programme setting, press ←/→ to choose LIST, then press OK in step 2. For details, see step 3 in "Checking/changing/cancelling timer settings" (page 64).

**Notes**

- When setting the timer with VPS/PDC signals, enter the start and stop times exactly as indicated in the TV programme guide. Otherwise, the VPS/PDC function\* won't work.
- If the VPS/PDC signal is too weak or the broadcasting station failed to transmit VPS/PDC signals, the VCR will start recording at the set time without using the VPS/PDC function\*.
- The ⊙ indicator flashes in the display window when you press I/⏪ with no tape inserted.
- The VPS/PDC function\* is automatically set to OFF for the timer recording of a satellite programme.
- The station name\* may not appear if the VCR does not receive station name information signals.

\* SLV-SE510K only

## Playing/searching at various speeds

### Before you start...

- Refer to "Index to parts and controls" for button locations.

Playback options	Operation
View the picture during fast-forward or rewind	During fast-forward, hold down <b>FF/▶▶</b> . During rewind, hold down <b>REW/◀◀</b> .
Play at high speed	<ul style="list-style-type: none"> <li>During playback, press <b>FF/▶▶</b> or <b>REW/◀◀</b> on the remote commander.</li> <li>During playback, hold down <b>FF/▶▶</b> or <b>REW/◀◀</b>. When you release the button, normal playback resumes.</li> </ul>
Play at twice the normal speed	During playback, press <b>x2</b> .
Play in slow motion	During playback, press <b>SLOW</b> .
Play frame by frame	During pause, press <b>FF/▶▶</b> or <b>REW/◀◀</b> on the remote commander. Hold down <b>FF/▶▶</b> or <b>REW/◀◀</b> to play one frame each second.
Rewind and start play	During stop, press <b>▶</b> (play) on the VCR while holding down <b>◀◀</b> on the VCR.

### To resume normal playback

Press **▶** PLAY.

### Tip

- Adjust the picture using the PROGRAM +/- buttons on the VCR if:
  - Streaks appear while playing in slow motion.
  - Bands appear at the top or bottom while pausing.
  - The picture shakes while pausing.
- To set tracking to the centre position, press both buttons (+/-) at the same time.

### Notes

- The sound is muted during these operations.
- In the LP mode, noise may appear or there may be no colour.
- If the playback mode mark doesn't appear on the TV screen, press **DISP** DISPLAY.

## Setting the recording duration time

After you have started recording in the normal way, you can have the VCR stop recording automatically after a specified duration.

### Before you start...

- Refer to "Index to parts and controls" for button locations.

#### 1 While recording, press **REC**.

The **⊖** indicator appears in the display window.

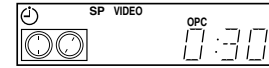

#### 2 Press **REC** repeatedly to set the duration time.

Each press advances the time in increments of 30 minutes.

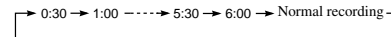

The tape counter decreases minute by minute to 0:00, then the VCR stops recording and turns off automatically.

### To extend the duration

Press **REC** repeatedly to set a new duration time.

### To cancel the duration

Press **REC** repeatedly until the **⊖** indicator disappears and the VCR returns to the normal recording mode.

### To stop recording

To stop the VCR while recording, press **STOP**.

### Note

- You cannot display the current tape time in the display window when setting the recording duration time.

## Synchronized Recording (SLV-SE510K only)

You can set the VCR to automatically record programmes from equipment such as a satellite tuner by connecting the equipment to the DECODER/ LINE-2 IN connector. The connected equipment must have a timer function for this feature to work.

When the connected equipment turns on, the VCR also automatically turns on and starts recording a programme from DECODER/LINE-2 IN.

### How to connect for Synchronized Recording

Connect the DECODER/LINE-2 IN connector of the VCR to the TV Scart connector of the satellite tuner. Then connect the LINE-1 (TV) connector of the satellite tuner to the TV.

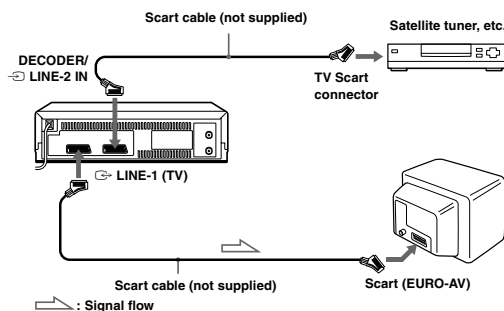

### Recording programmes using the Synchronized Recording function

#### Before you start...

- Insert a tape with its safety tab in place. Make sure the tape is longer than the total recording time.
- Set DECODER/LINE2 to LINE2 in the OPTIONS-2 menu (see page 73).
- Refer to "Index to parts and controls" for button locations.

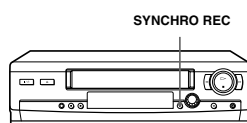

#### 1 Press INPUT SELECT or PROG +/- to display "L2" in the display window.

2 Set the timer on the connected equipment to the time of the programme you want to record, then turn it off.

3 Press SP/LP to select the tape speed.

#### 4 Hold down SYNCHRO REC for more than two seconds.

The SYNCHRO REC button lights up and the VCR stands by for recording.

The VCR automatically turns on and starts recording when it receives an input signal from the connected equipment.

The VCR automatically stops recording when the tape reaches the end or when the connected equipment stops transmitting an input signal.

### To cancel the Synchronized Recording function

Press SYNCHRO REC. The SYNCHRO REC button turns off.

### To stop recording

Press **STOP** while recording.

### Notes

- This function may not work with some types of satellite tuners.
- Some TVs or other equipment with timer functions will automatically turn off if no operation is performed within a certain amount of time. In this case, the Synchronized Recording also stops automatically.
- When the connected equipment turns on while the SYNCHRO REC button is lit, recording starts automatically.
- If the settings for timer recording and Synchronized Recording overlap, the programme that starts first has priority and the second programme starts recording only after the first programme has finished.
- The Auto Clock Set function does not work while the VCR stands by for Synchronized Recording.

## Checking/changing/cancelling timer settings

### Before you start...

- Turn on your TV and set it to the video channel.
- Refer to "Index to parts and controls" for button locations.

- 1 Press I/⏻ to turn on the VCR.
- 2 Press MENU, then press ↑/↓ to highlight LISTS and press OK.

- 3 Press ↑/↓ to highlight TIMER LIST, then press OK:

- If you want to change or cancel a setting, go on to the next step.
- If you do not need to change or cancel the settings, press MENU, then turn off the VCR to return to recording standby.

- 4 Press ↑/↓ to select the setting you want to change or cancel, then press OK. The selected setting appears in the TIMER menu.

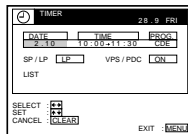
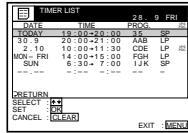

- 5 • To change the setting, press ←/→ to highlight the item you want to change, then press ↑/↓ to reset it.
  - To cancel the setting, press CLEAR.
- 6 Press MENU to exit the menu. If any settings remain, turn off the VCR to return to recording standby.

### When the timer settings overlap

The programme that starts first has priority and the second programme starts recording only after the first programme has finished. If the programmes start at the same time, the programme listed first in the menu has priority.

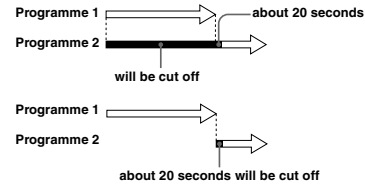

### Tip

- In step 6 above, you can check the TIMER LIST by selecting LIST and pressing OK. Press MENU to exit the TIMER LIST.

## Searching using the Smart Search function

If you record multiple programmes on a tape, use the Smart Search function to see what has been recorded on your tape. You can see information such as date, time, and programme position of programmes recorded on a tape. You can also start playback directly from the selected programme using the SMART SEARCH screen.

All programmes are listed on the screen, regardless of how the programme was recorded.

The data of the last tape inserted into the VCR is automatically stored in memory. If you want to recall the latest data screen, select LATEST DATA in the SMART SEARCH screen (see page 67).

### Before you start...

- Turn on your TV and set it to the video channel.
- Refer to "Index to parts and controls" for button locations.

- 1 After recording, press I/⏻ to turn on the VCR.
- 2 Press SMART SEARCH.
- 3 Press ↑/↓/←/→ to select the programme you want to start viewing.

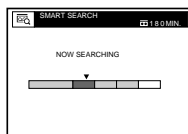
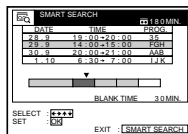

- 4 Press OK. The VCR starts searching, and playback starts automatically from the beginning of the selected programme.

### To stop searching

Press ■ STOP.

### To exit the SMART SEARCH screen

Press SMART SEARCH.

### To record in a blank space

Blank space on the tape will appear as a blank row in the SMART SEARCH screen. Select the last blank row in step 3, then press OK. The VCR rewinds/fast-forwards the tape to the beginning of the blank space, then stops. Start recording. Note that "BLANK TIME" and the remaining time indication only refers to the length of the last blank space.

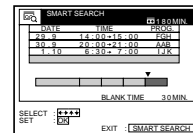

### To recall the latest data screen after you remove the tape

You can display the data of the last tape used to record a programme, even after you have removed the tape.

If you reinsert the tape and record additional programmes, be sure to select LATEST DATA. Otherwise, all of the data for the tape is deleted.

- 1 Reinsert the last tape that you used to record a programme.
- 2 Press SMART SEARCH.

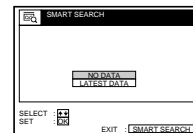

- 3 Press ↑/↓ to highlight LATEST DATA. If you want to reset the latest data screen, highlight NO DATA and press OK, then record a programme.

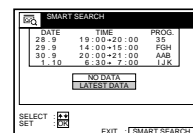

- 4 Press OK. The latest data stored in the VCR's memory is displayed.

### Tips

- You can store information for up to 24 programmes on a single list.
- While recording, you can display the SMART SEARCH screen using the SMART SEARCH button. If you decide to stop recording, press SMART SEARCH to make the SMART SEARCH screen disappear first. Then press ■ STOP.

## Notes

- You cannot use this function unless the clock is set.
- Depending on the tape, the total or remaining time may not appear correctly.
- If many short programmes are recorded on a tape, multiple programmes may be included in a single block. In this case, only the latest programme information will appear in the SMART SEARCH screen.
- Blank time is measured from the end of the last recorded programme to the end of the tape. However, if you eject the tape and then make a new recording on the same tape, the original recorded programme(s) is displayed as a blank space.
- If no information is stored in the VCR's memory, LATEST DATA does not appear in the SMART SEARCH screen.
- The station name\* may not appear if the VCR does not receive station name information signals.
- If you start recording a programme "D" from the middle of a previously recorded programme "A" and into another previously recorded programme "B," the Smart Search information for the second programme "B," which is recorded over, is deleted.

### Originally recorded programmes



### Recording the programme "D" over the programme "A" and "B"

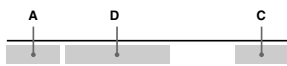

\* SLV-SE510K only

## Notes

- You can adjust the tracking for an NTSC-recorded tape but the tracking meter won't be displayed.
- With the Auto Long Play function on, the OPC function will work only in SP mode. If the tape speed automatically switches from SP to LP, the OPC function turns off. If, however, the entire programme is recorded in LP mode, the OPC function will work.
- There is a delay of about ten seconds before the VCR actually starts recording while the VCR analyses the tape. To avoid the delay, first set the VCR to recording pause (the OPC indicator flashes slowly) and press ● REC to have the VCR analyse the tape (the OPC indicator flashes rapidly) and return to recording pause. After the OPC indicator stops flashing, press ■ PAUSE to start recording immediately. If you want to start recording quickly without using the OPC function, first set the VCR to recording pause (the OPC indicator flashes slowly) and press ■ PAUSE again to start recording.

## Adjusting the picture

### Adjusting the tracking

Although the VCR automatically adjusts the tracking when playing a tape (the  indicator flashes in the display window, then turns off), distortion may occur if the recording is in poor condition. In this case, manually adjust the tracking.

During playback, press PROGRAM +/- on the VCR to display the tracking meter. The distortion should disappear as you press one of the two buttons (the  indicator lights up). To resume automatic tracking adjustments, eject the tape and re-insert it.

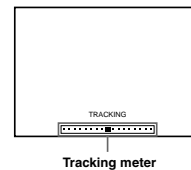

Tracking meter

### About the Optimum Picture Control (OPC) function

The Optimum Picture Control (OPC) function automatically improves recording and playback quality by adjusting the VCR to the condition of the video heads and tape. To maintain better picture quality, we recommend that you set OPC to ON in the OPTIONS-1 menu (the OPC indicator lights up in the display window). For details, see page 72.

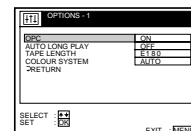

### OPC playback

The OPC function automatically works on all types of tapes, including rental tapes and tapes that were not recorded with OPC.

### OPC recording

Whenever you insert a tape and start recording for the first time, the VCR adjusts to the tape using the OPC function (the OPC indicator flashes rapidly). This adjustment is retained until the tape is ejected.

### To deactivate the OPC function

Set OPC to OFF in the OPTIONS-1 menu. The OPC indicator in the display window turns off.

### Tip

- To set tracking to the centre position, press the PROGRAM + and - buttons on the VCR at the same time.

continued

## Reducing the VCR's power consumption

You can turn off the indicators in the display window when the VCR is off (standby mode) to reduce the VCR's power consumption.

- Press MENU, then select OPTIONS and press OK.
- Press ↑/↓ to highlight OPTIONS-2, then press OK.
- Press ↑/↓ to select POWER SAVE, then press OK.

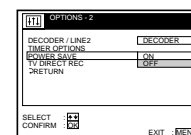

- Press ↑/↓ to highlight ON, then press OK.
- Press MENU to return to the original screen.

### Tip

- To ensure that the power consumption is at the lowest possible level, set DECODER/LINE2 in the OPTIONS-2 menu to LINE2 (page 73).

### Note

- When the VCR stands by for recording, the indicators in the display window remain lit even when POWER SAVE is set to ON.

## Changing menu options

- 1 Press MENU, then select OPTIONS and press OK.

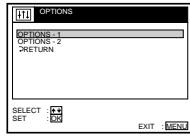

- 2 Press ↑/↓ to highlight OPTIONS-1 or OPTIONS-2, then press OK.

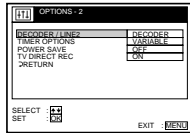
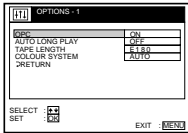

- 3 Press ↑/↓ to select the option, then press OK.

- 4 Press ↑/↓ to change the setting, then press OK.

- 5 Press MENU to return to the original screen.

### Menu choices

Initial settings are indicated in bold print.

#### OPTIONS-1

Menu option	Set this option to
OPC	<ul style="list-style-type: none"> <li>• <b>ON</b> to switch on the OPC (Optimum Picture Control) function and improve picture quality.</li> <li>• <b>OFF</b> to switch off OPC.</li> </ul>
AUTO LONG PLAY	<ul style="list-style-type: none"> <li>• <b>ON</b> to change the timer recording tape speed automatically to the LP mode when the remaining tape length becomes shorter than the recording time. Note that for AUTO LONG PLAY to work correctly, the TAPE LENGTH setting must be accurate.</li> <li>• <b>OFF</b> to keep the set tape speed.</li> </ul>
TAPE LENGTH	<ul style="list-style-type: none"> <li>• <b>E180</b> to use an E-180 or shorter type tape.</li> <li>• <b>E195</b> to use an E-195 type tape.</li> <li>• <b>E240</b> to use an E-240 type tape.</li> <li>• <b>E300</b> to use an E-300 type tape.</li> </ul>

Menu option	Set this option to
COLOUR SYSTEM	<ul style="list-style-type: none"> <li>• <b>AUTO</b> to set the colour system automatically.</li> <li>• <b>PAL</b> to play back a tape recorded in the PAL colour system.</li> <li>• <b>MESECAM</b> to play back a tape recorded in the MESECAM colour system.</li> </ul> <p>If you press ▲ EJECT or turn the VCR off, COLOUR SYSTEM will be reset to AUTO.</p>

#### OPTIONS-2

Menu option	Set this option to
DECODER/LINE2	<ul style="list-style-type: none"> <li>• <b>DECODER</b> to use the DECODER/LINE-2 IN connector as the Canal Plus decoder connector.</li> <li>• <b>LINE2</b> to use the DECODER/LINE-2 IN connector as the line input connector.</li> </ul>
TIMER OPTIONS*	<ul style="list-style-type: none"> <li>• <b>VARIABLE</b> to display the TIMER METHOD menu for selecting STANDARD or SHOWVIEW when pressing the ⌚ TIMER button.</li> <li>• <b>STANDARD</b> to display the TIMER menu when pressing the ⌚ TIMER button.</li> <li>• <b>SHOWVIEW</b> to display the SHOWVIEW menu when pressing the ⌚ TIMER button.</li> </ul> <p>For details, see page 53 and 57.</p>
POWER SAVE	<ul style="list-style-type: none"> <li>• <b>ON</b> to turn off the indicators in the display window during standby mode to reduce the VCR's power consumption to a minimum. To ensure that power consumption is at the lowest possible level, set DECODER/LINE2 in OPTIONS-2 to LINE2.</li> <li>• <b>OFF</b> to turn on the indicators in the display window while the VCR is standing by.</li> </ul>
TV DIRECT REC*	<ul style="list-style-type: none"> <li>• <b>ON</b> to activate the TV Direct Rec function.</li> <li>• <b>OFF</b> to deactivate it.</li> </ul>

#### Note

- When the VCR stands by for recording, the indicators in the display window remain lit even when POWER SAVE is set to ON.

\* SLV-SE510K only

## Editing with another VCR

### How to connect to record on this VCR

Connect the line outputs of the other VCR to the LINE IN connector or jacks of this VCR. Refer to the examples A or B and choose the connection that best suits your VCR.

#### Example A

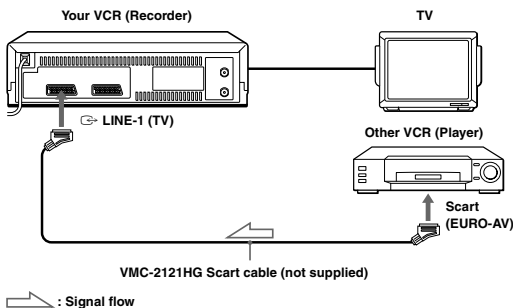

#### Example B

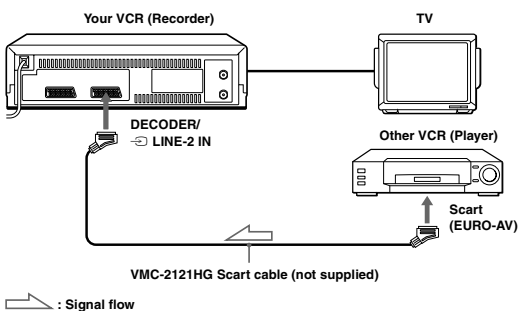

#### Notes

- If you connect this VCR to both the LINE IN and LINE OUT jacks of the other VCR, select the input correctly to prevent a humming noise.
- If the other VCR does not have a Scart (EURO-AV) connector, use the VMC-2106HG cable instead and connect the cable to the line out jacks of the other VCR.
- When you connect another VCR to the DECODER/LINE-2 IN connector, set DECODER/LINE2 to LINE2 in the OPTIONS-2 menu.

### Operation (when recording on this VCR)

#### Before you start editing

- Turn on your TV and set it to the video channel.
- Press INPUT SELECT to display the connected line in the display window.
- Press SP/LP to select the tape speed, SP or LP.

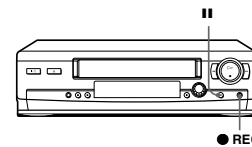

- 1 Insert a source tape with its safety tab removed into the other (playback) VCR. Search for the point to start playback and set it to playback pause.
- 2 Insert a tape with its safety tab in place into this (recording) VCR. Search for the point to start recording and press ⏸ (pause).
- 3 Press ● REC on this VCR to set it to recording pause.
- 4 To start editing, press the ⏸ (pause) buttons on both VCRs at the same time.

#### To stop editing

Press the ■ (stop) buttons on both VCRs.

#### Tip

- To cut out unwanted scenes while editing, press ⏸ (pause) on this VCR when an unwanted scene begins. When it ends, press ⏸ (pause) again to resume recording.

#### Note

- If you start editing following the procedure above, the VCR won't start recording with the OPC function. To record a tape with the OPC function, press ● REC again during recording pause in step 3 so the VCR analyses the tape. Then, press ⏸ (pause) after the OPC indicator stops flashing to start recording. If you press ⏸ (pause) before the OPC indicator stops flashing, the OPC function is cancelled.

## SECTION 2 DISASSEMBLY

**Note:** Follow the disassembly procedure in the numerical order given.

### 2-1. UPPER CASE REMOVAL

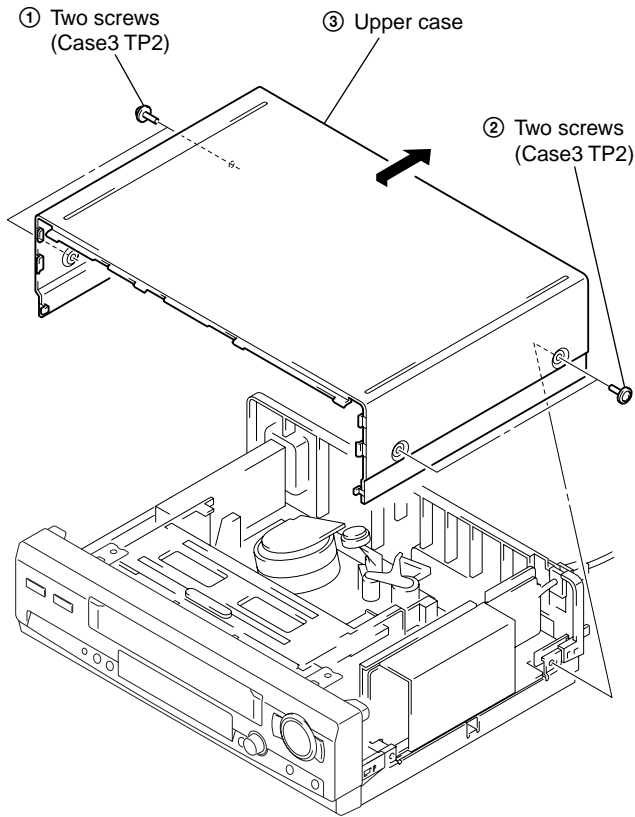

### 2-3. POWER BLOCK (ETXNY272E2D) REMOVAL

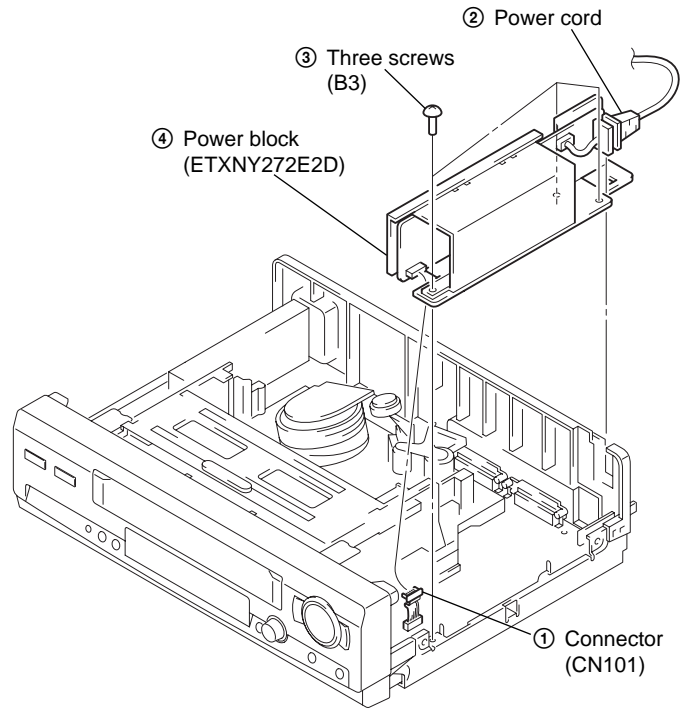

### 2-2. FRONT PANEL SECTION REMOVAL

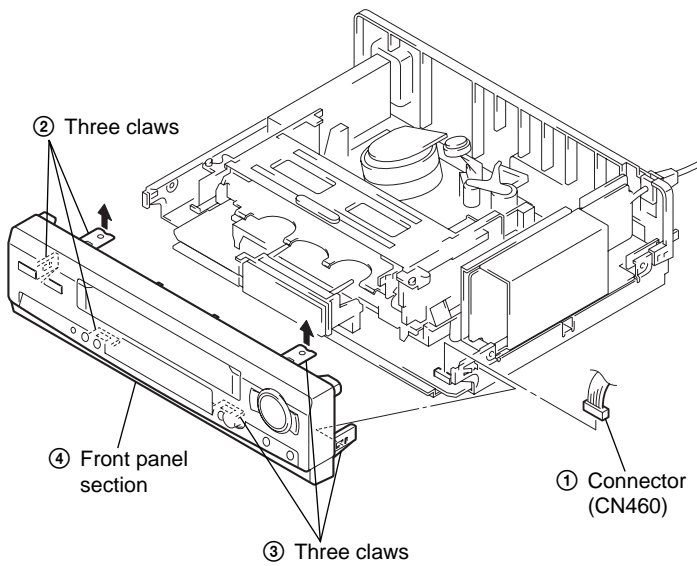

### 2-4. REAR PANEL REMOVAL

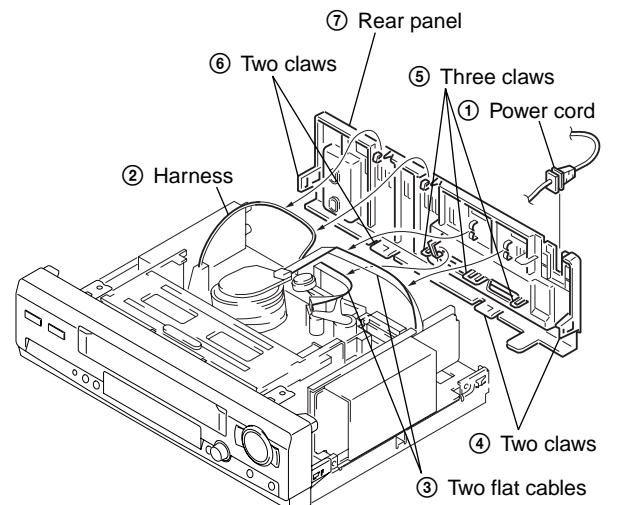

## 2-5. MECHANISM DECK REMOVAL

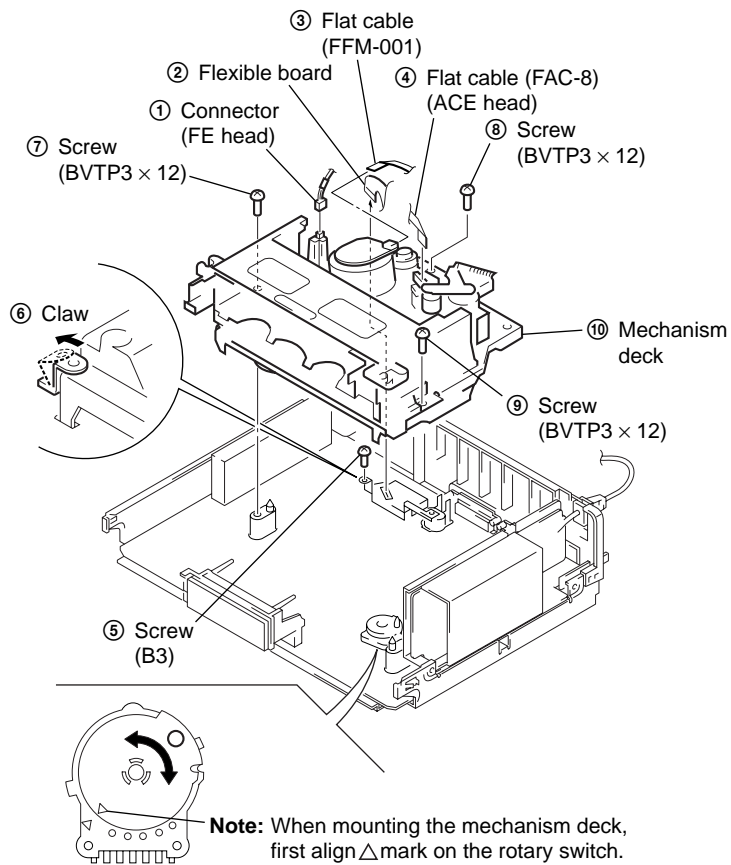

## 2-6. MA-401 BOARD REMOVAL

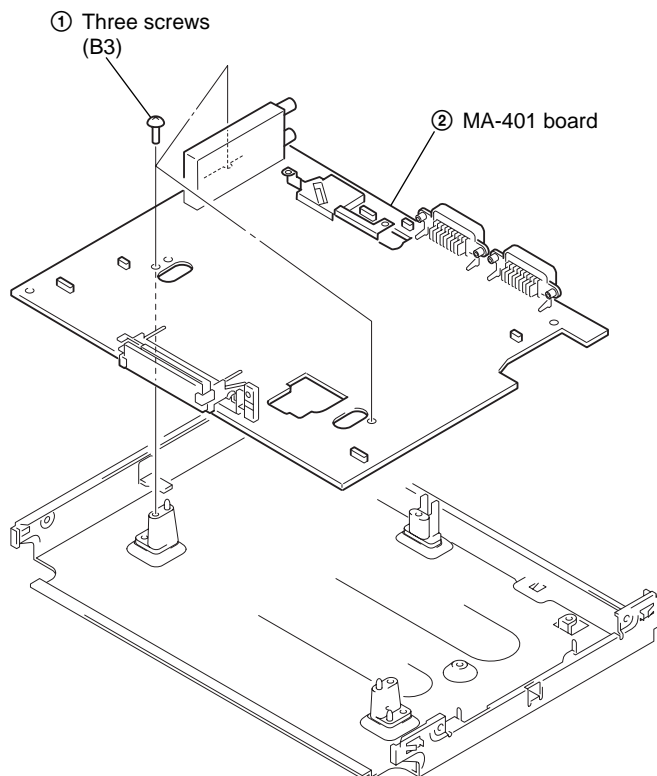



**2-7. INTERNAL VIEWS**

Drum assembly (M901) (DZH-92D-R)  
 1-772-361-11 (SE310)  
 Drum assembly (M901) (DZH-93D-R)  
 1-772-362-11 (SE410/SE510)

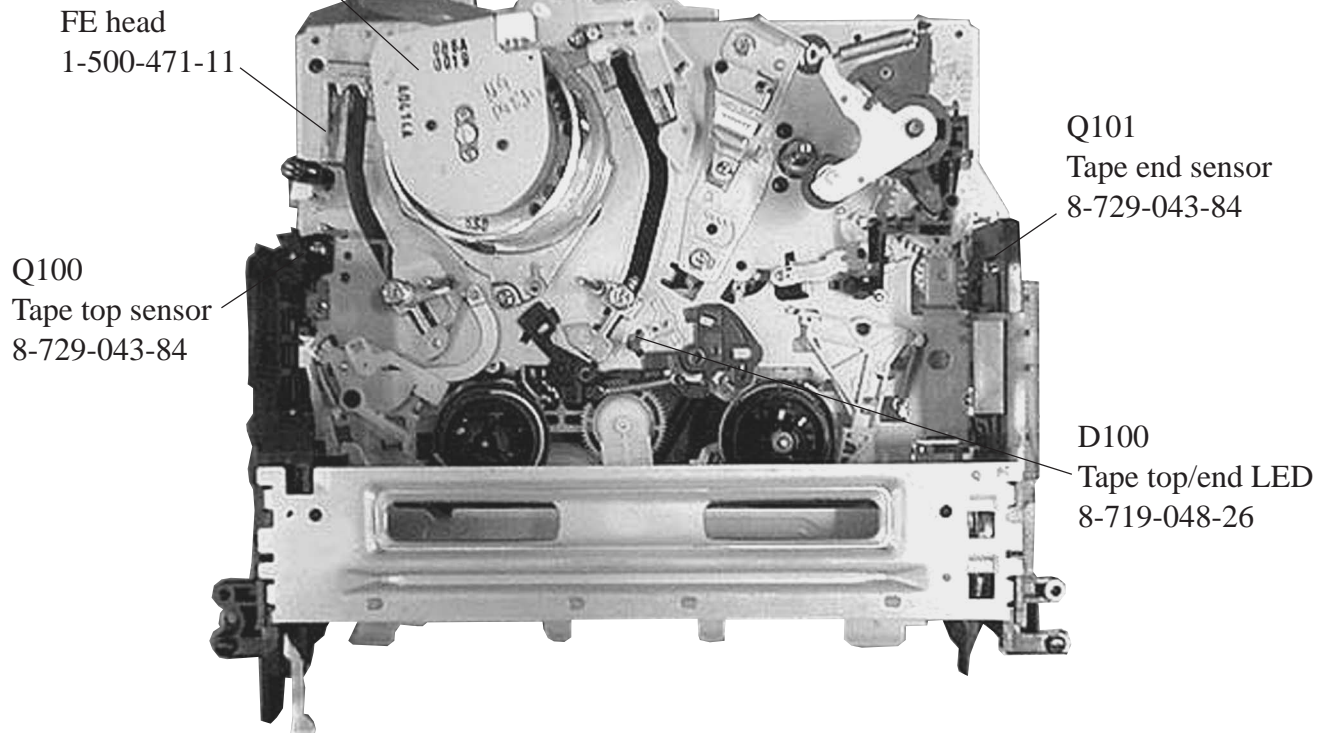

Drum assembly (M901) (DZH-92D-R)  
 1-772-361-11 (SE310)  
 Drum assembly (M901) (DZH-93D-R)  
 1-772-362-11 (SE410/SE510)

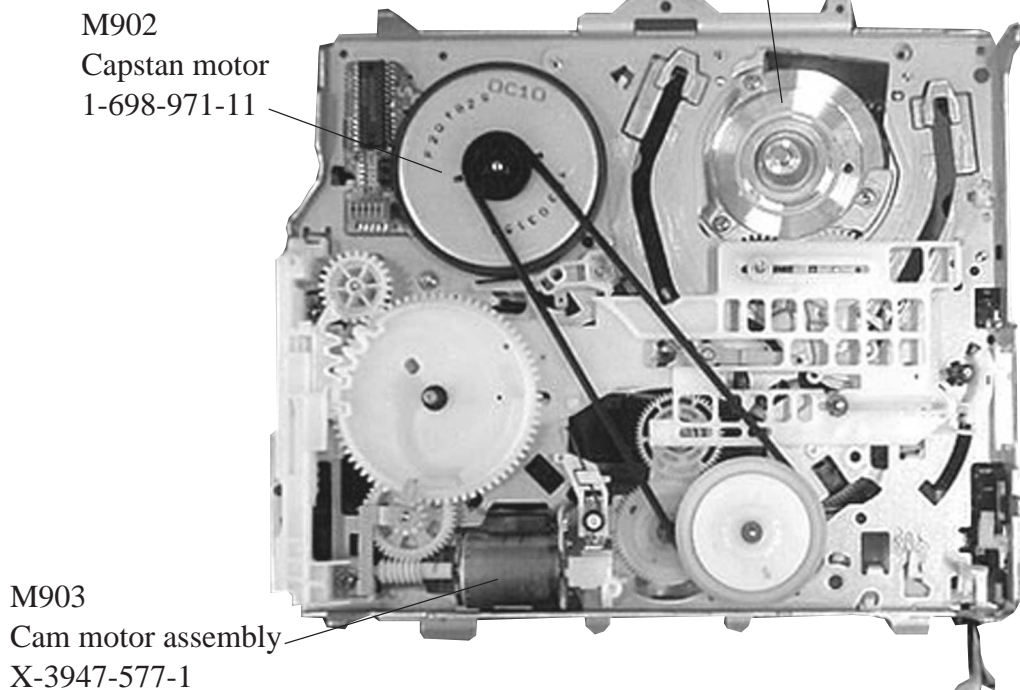

## 2-8. CIRCUIT BOARDS LOCATION

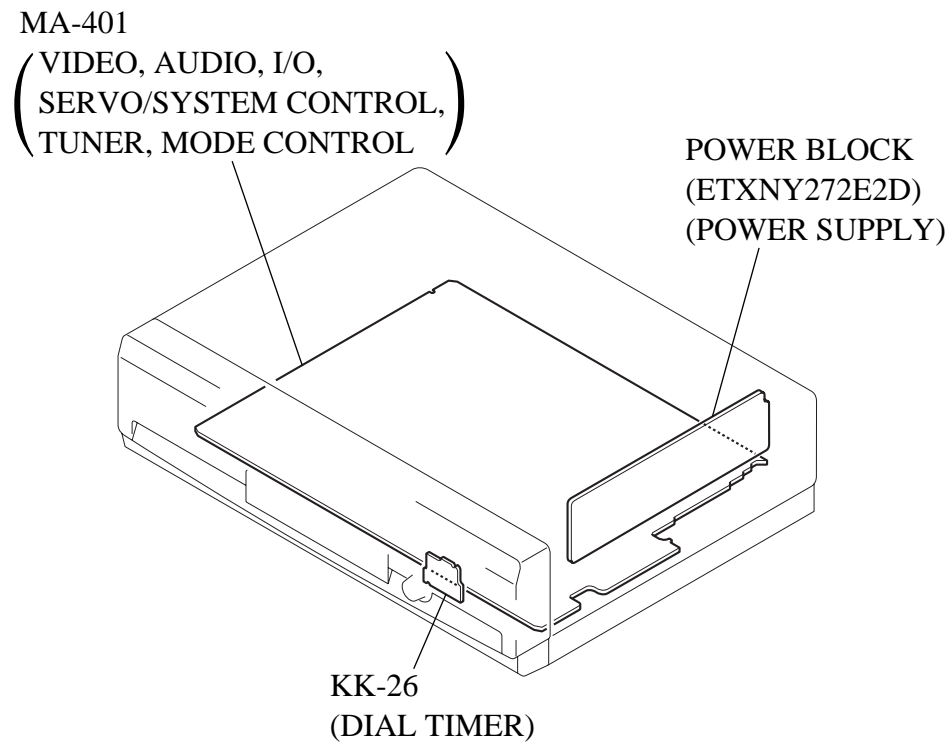

SECTION 3  
BLOCK DIAGRAMS

3-1. OVERALL BLOCK DIAGRAM

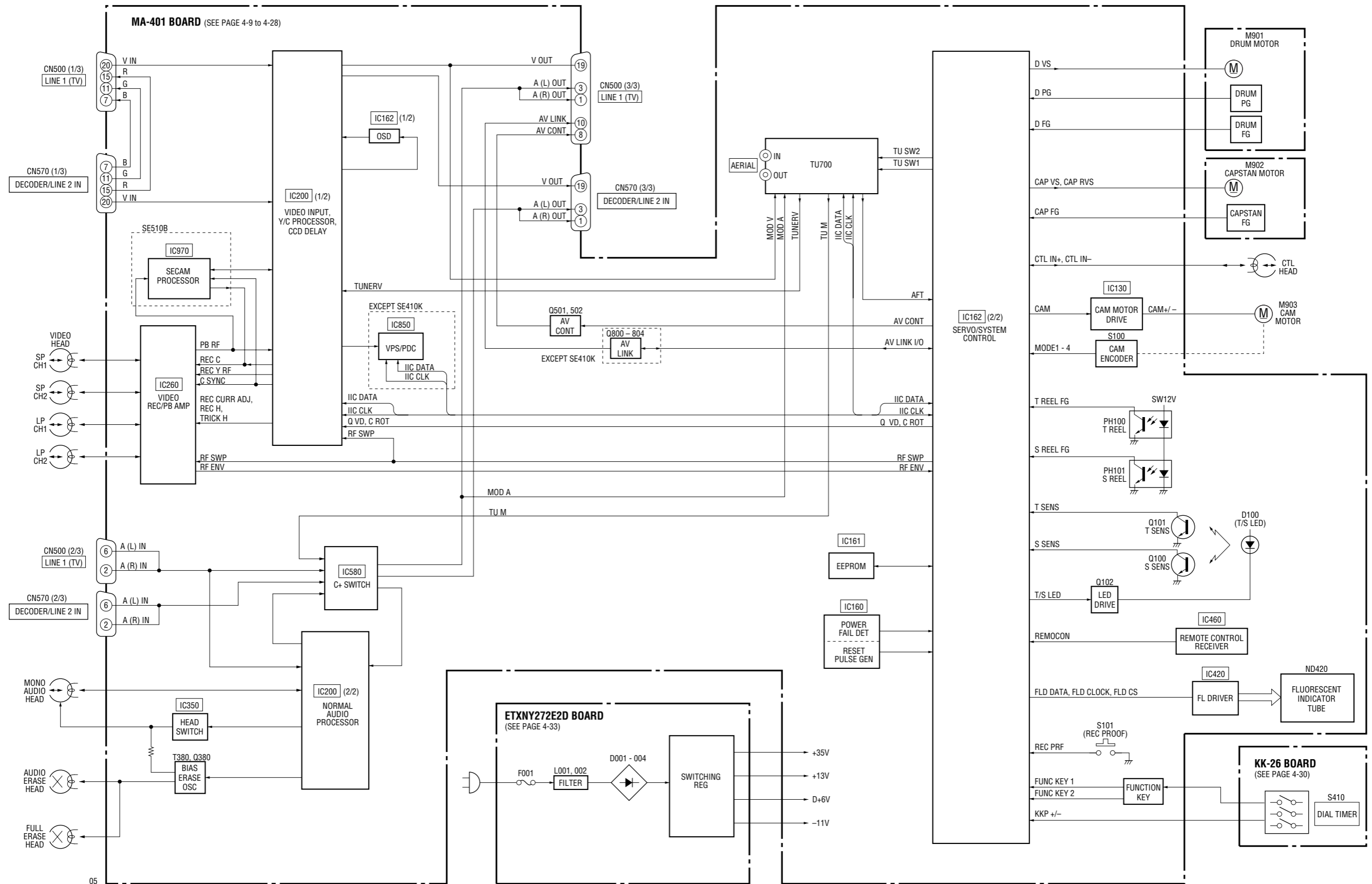

05

3-2. VIDEO BLOCK DIAGRAM

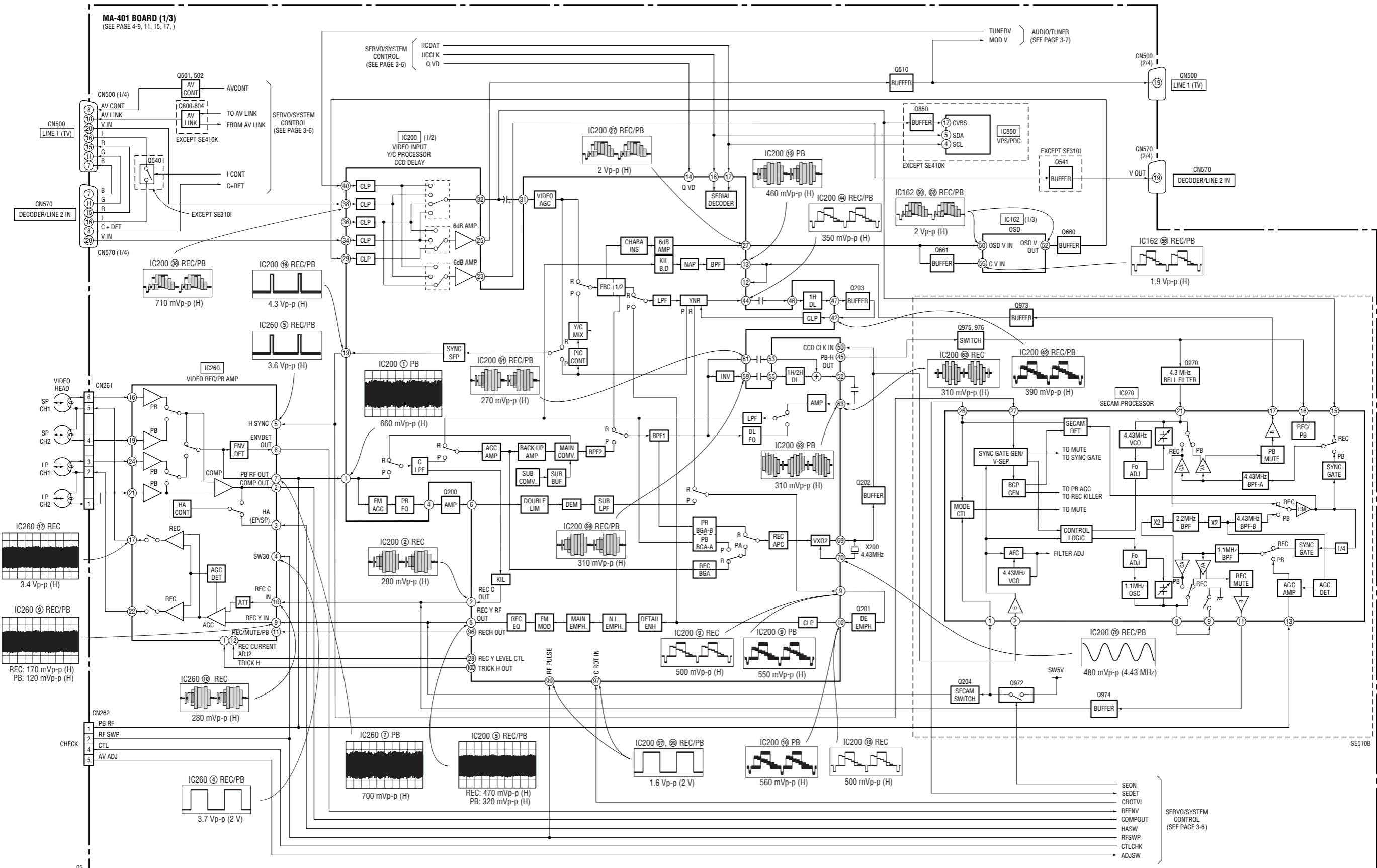

3-3. SERVO/SYSTEM CONTROL BLOCK DIAGRAM

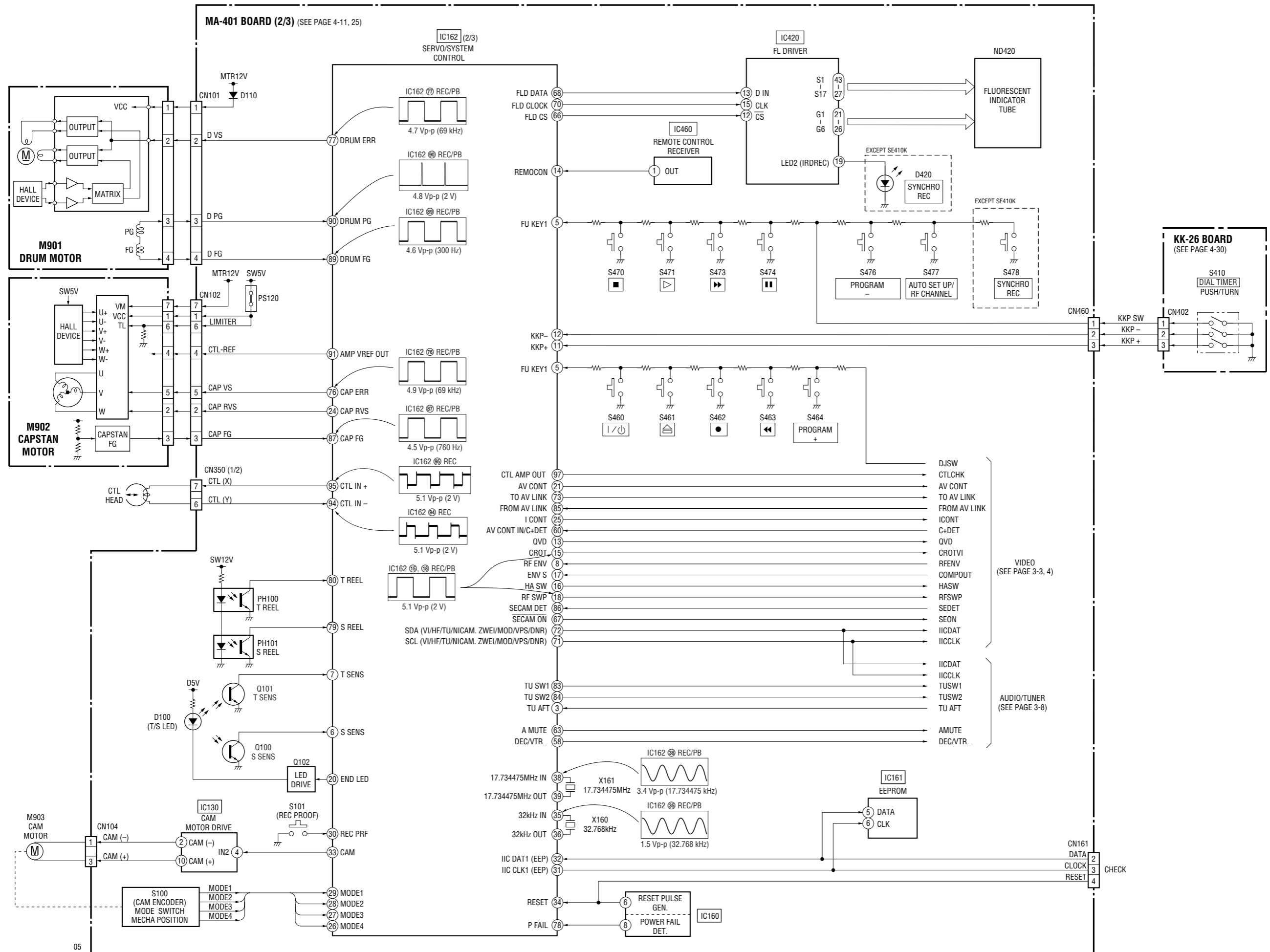

3-4. AUDIO/TUNER BLOCK DIAGRAM

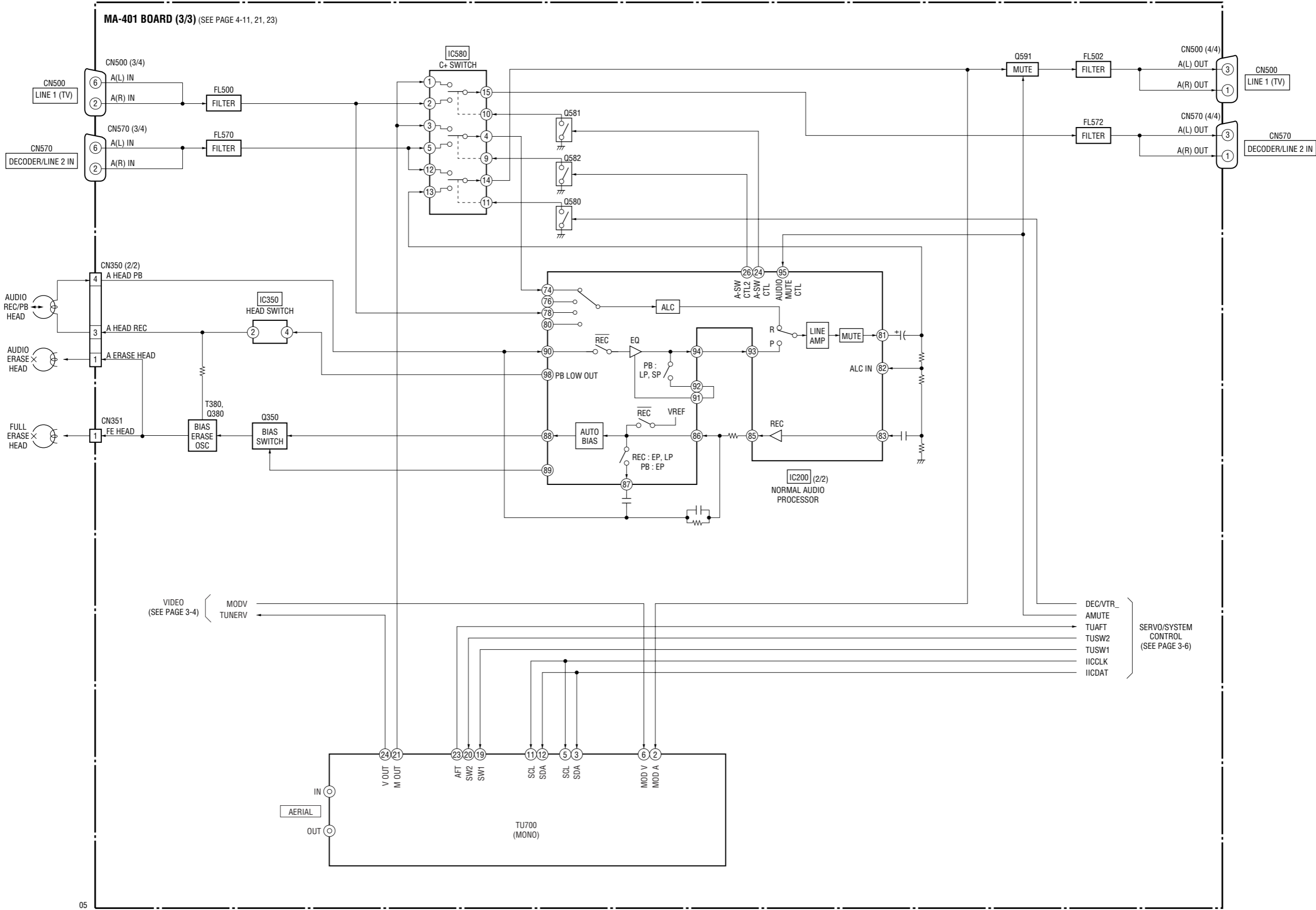

05

3-5. POWER BLOCK DIAGRAM

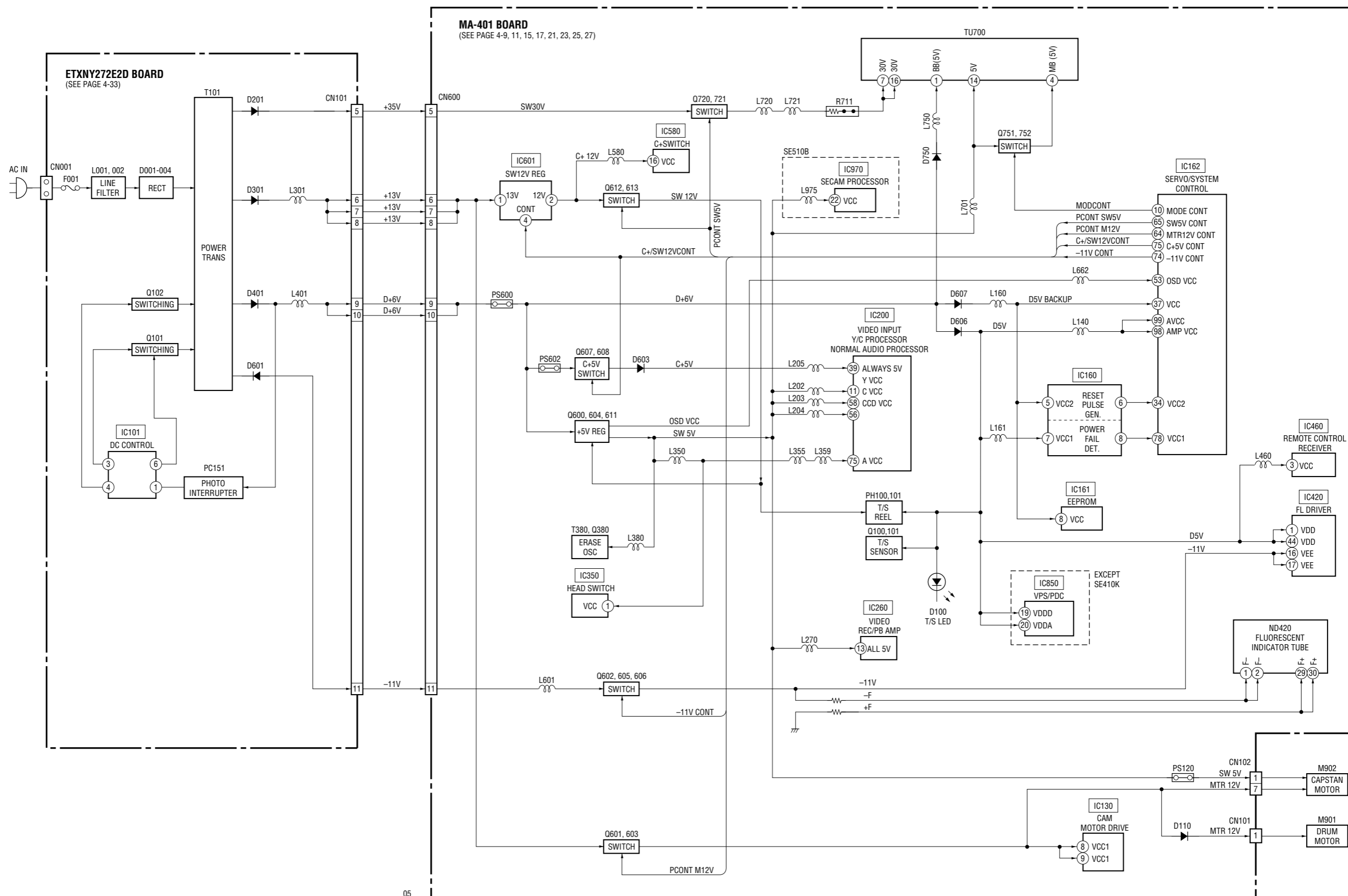

05



## SECTION 4

### PRINTED WIRING BOARDS AND SCHEMATIC DIAGRAMS







#### THIS NOTE IS COMMON FOR PRINTED WIRING BOARDS AND SCHEMATIC DIAGRAMS.

(In addition to this, the necessary note is printed in each block.)

#### For printed wiring board:

-  : indicates a lead wire mounted on the component side.
-  : indicates a lead wire mounted on the printed side.
-  : Pattern from the side which enables seeing.  
(The other layers' patterns are not indicated.)

#### For schematic Diagram:

- Caution when replacing chip parts.  
New parts must be attached after removal of chip.  
Be careful not to heat the minus side of tantalum capacitor, because it is damaged by the heat.
- All resistors are in ohms,  $\frac{1}{4} W$  (Chip resistors :  $\frac{1}{10} W$ ) unless otherwise specified.  
k $\Omega$  : 1000 $\Omega$ , MW : 1000k $\Omega$ .
- All capacitors are in  $\mu F$  unless otherwise noted. pF :  $\mu\mu F$   
50V or less are not indicated except for electrolytics and tantalums.
- All variable and adjustable resistors have characteristic curve B, unless otherwise noted.
-  : nonflammable resistor.
-  : fusible resistor.
-  : panel designation.
-  : internal component.
-  : adjustment for repair.
-  : B+ Line.
-  : B- Line.
- Circled numbers refer to waveforms.
- Voltages are dc between measurement point.
- Readings are taken with a color-bar signal input.
- Readings are taken with a digital multimeter (DC 10MW).
- Voltage variations may be noted due to normal production tolerances.

**Note:** The components identified by mark  $\triangle$  or dotted line with mark  $\triangle$  are critical for safety.  
Replace only with part number specified.

When indicating parts by reference number, please include the board name.



4-1. FRAME SCHEMATIC DIAGRAM

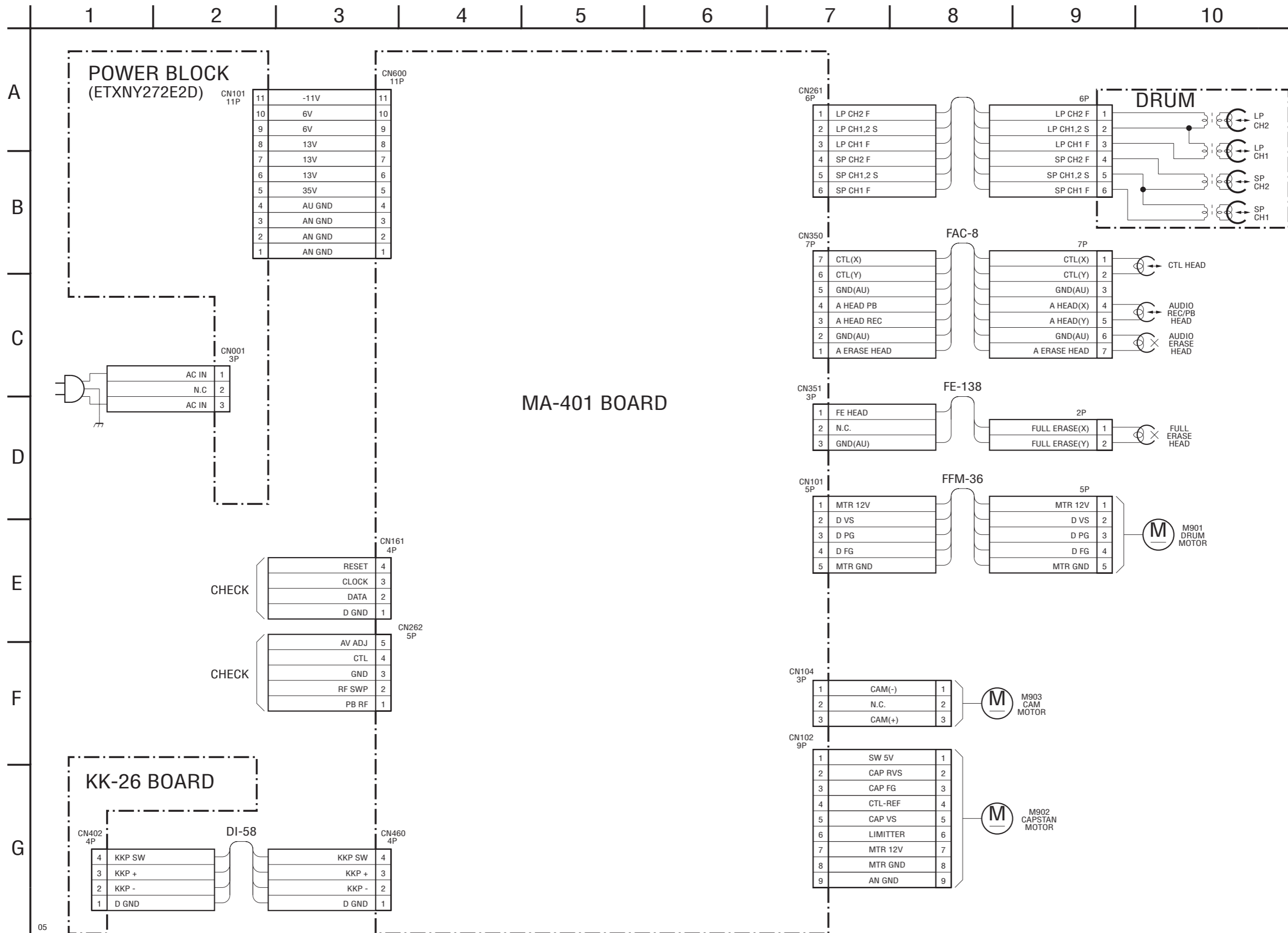

05

4-2. PRINTED WIRING BOARDS AND SCHEMATIC DIAGRAMS

MA-401 (VIDEO, AUDIO, I/O, SERVO/SYSTEM CONTROL, TUNER, MODE CONTROL) PRINTED WIRING BOARD

- Ref. No.: MA-401 board; 1,000 series -

There are a few cases that the part isn't mounted in this model is printed on this diagram.

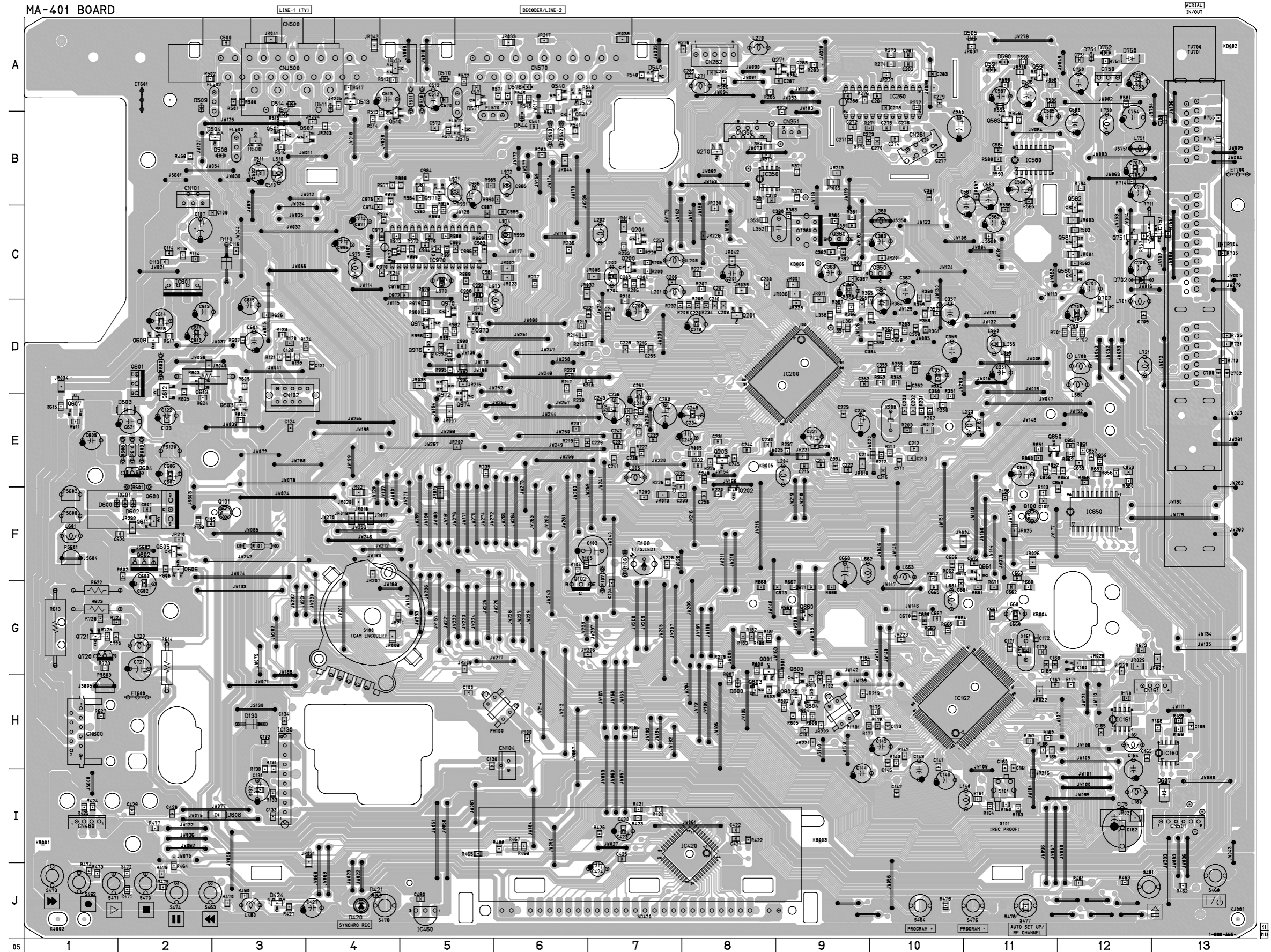

4-5

4-6

MA-401 BOARD

CN101	B-2	Q100	F-11
CN102	E-3	Q101	F-3
CN104	H-6	Q102	F-6
CN161	H-13	Q200	C-7
CN261	B-10	Q201	D-8
CN262	A-8	Q202	F-8
CN350	B-8	Q203	E-8
CN351	B-9	Q204	C-7
CN460	I-1	Q350	C-10
CN500	A-3	Q380	C-9
CN570	A-6	Q501	B-3
CN600	H-1	Q502	B-3
		Q510	B-4
D100	F-7	Q540	A-6
D110	C-3	Q541	B-6
D420	J-4	Q580	C-12
D421	J-4	Q581	C-12
D424	J-3	Q582	B-12
D500	B-3	Q583	B-11
D504	B-3	Q591	A-11
D508	B-3	Q600	F-2
D511	A-4	Q601	D-2
D512	B-3	Q602	F-2
D513	A-4	Q603	E-3
D514	A-3	Q604	E-2
D515	A-4	Q605	F-2
D540	A-7	Q606	F-2
D542	A-6	Q607	E-1
D544	B-6	Q608	D-2
D570	A-5	Q611	F-2
D571	A-5	Q612	D-2
D575	B-5	Q613	D-2
D576	A-6	Q660	G-9
D590	A-11	Q661	F-11
D591	A-11	Q720	G-1
D600	F-1	Q721	G-1
D601	F-2	Q751	C-12
D602	F-2	Q752	C-13
D603	E-2	Q800	G-9
D606	I-3	Q801	G-8
D607	I-13	Q802	H-9
D702	C-12	Q803	H-8
D750	A-12	Q804	H-9
D800	H-8	Q850	E-11
		Q970	D-5
IC130	H-3	Q972	D-5
IC160	H-13	Q973	D-5
IC161	H-12	Q974	E-5
IC162	H-11	Q975	D-5
IC200	D-9	Q976	D-5
IC260	A-10		
IC350	B-8		
IC420	I-8		
IC460	J-5		
IC580	B-11		
IC601	C-2		
IC850	F-12		
IC970	C-5		

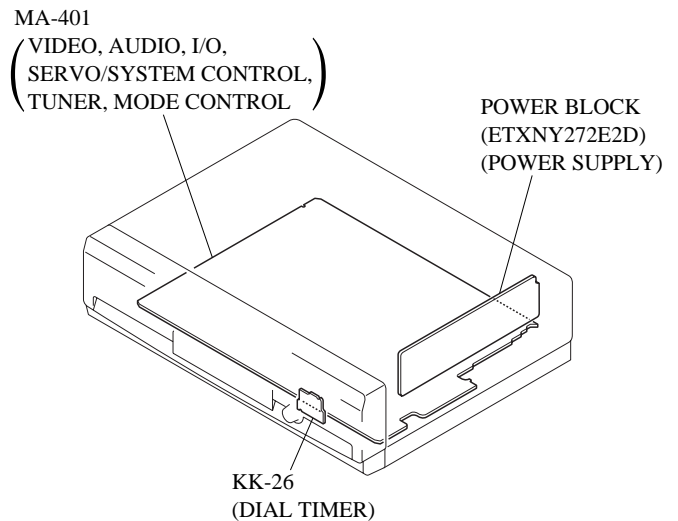

• Waveforms

① IC260 ⑰ REC

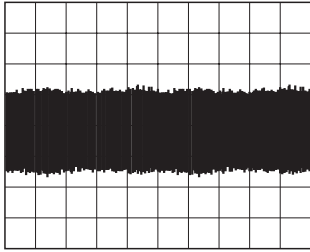

3.4 Vp-p (H)

⑤ IC260 ⑤ REC/PB

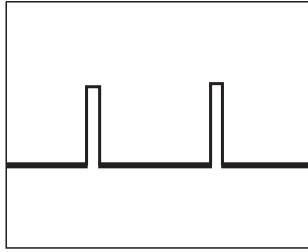

3.6 Vp-p (H)

② IC260 ⑩ REC

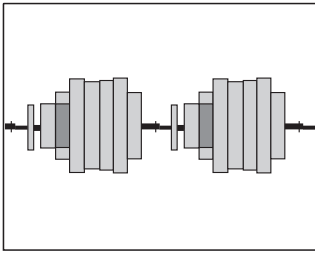

280 mVp-p (H)

⑥ IC260 ④ REC/PB

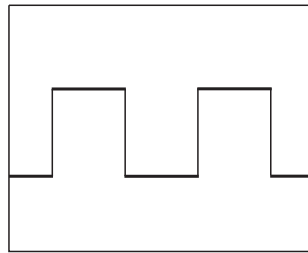

3.7 Vp-p (2 V)

③ IC260 ⑨ REC/PB

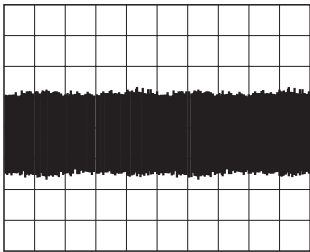

REC : 170 mVp-p (H)  
PB : 120 mVp-p (H)

④ IC260 ⑦ PB

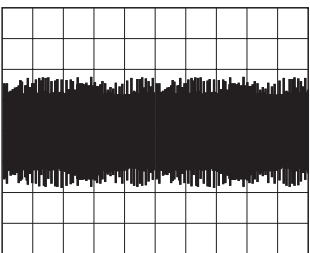

700 mVp-p (H)

MA-401 (HEAD AMP) SCHEMATIC DIAGRAM • See page 4-5 for printed wiring board.

- Ref. No.: MA-401 board; 1,000 series -

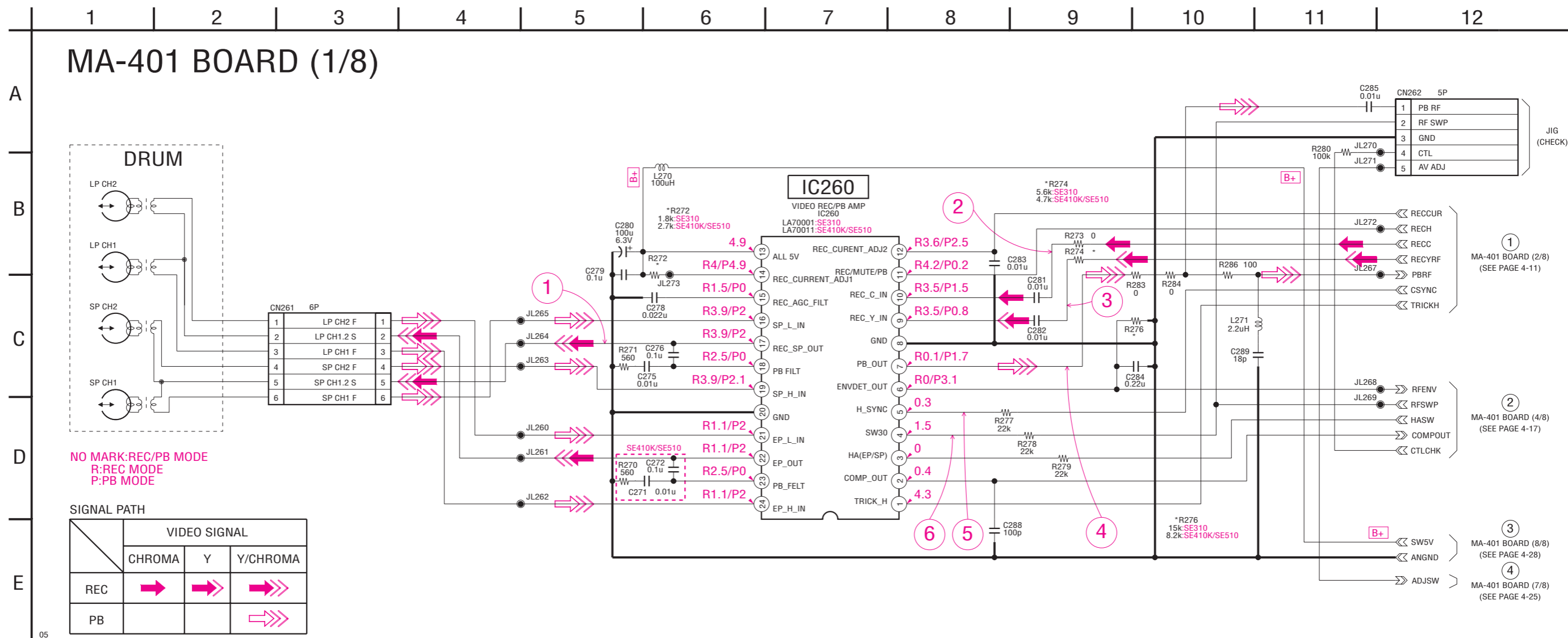

MA-401 (VIDEO, AUDIO) SCHEMATIC DIAGRAM • See page 4-5 for printed wiring board.

- Ref. No.: MA-401 board; 1,000 series -

1 2 3 4 5 6 7 8 9 10 11 12 13 14 15 16 17 18 19

A  
B  
C  
D  
E  
F  
G  
H  
I  
J  
K  
L

MA-401 BOARD (2/8)

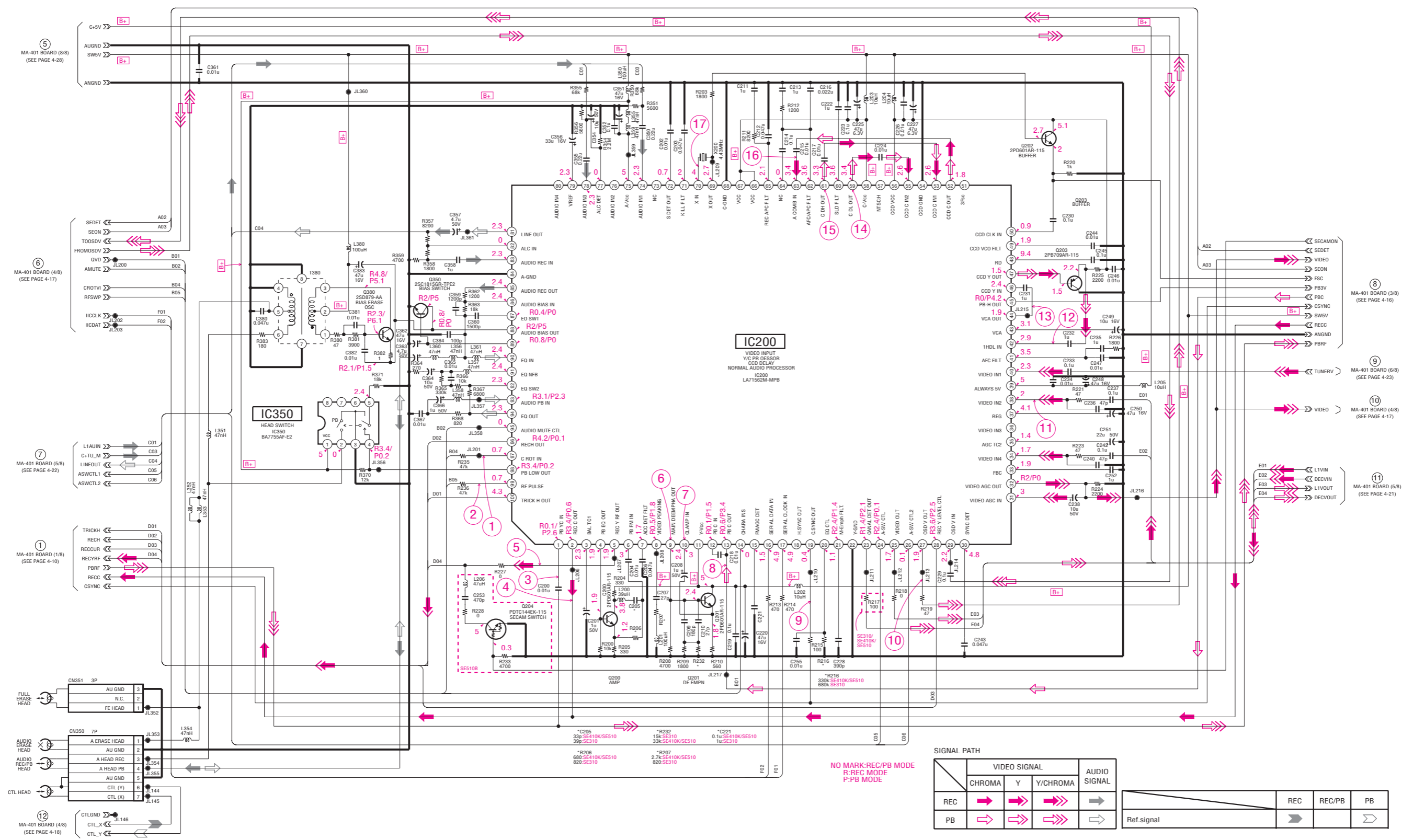

• Waveforms

① IC200 ⑨ REC/PB

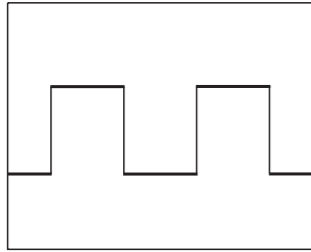

1.6 Vp-p (2 V)

⑥ IC200 ⑨ REC

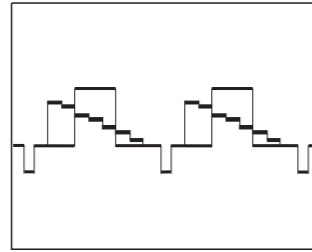

500 mVp-p (H)

⑨ IC200 ⑱ REC/PB

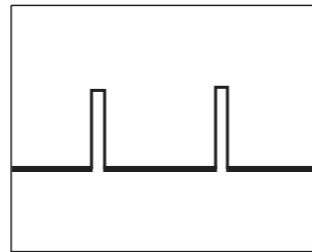

4.3 Vp-p (H)

⑭ IC200 ⑥⑨ REC/PB

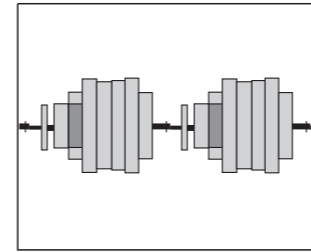

310 mVp-p (H)

② IC200 ⑨⑨ REC/PB

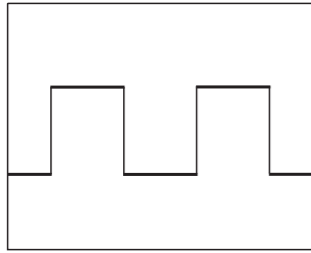

1.6 Vp-p (2 V)

⑥ IC200 ⑨ PB

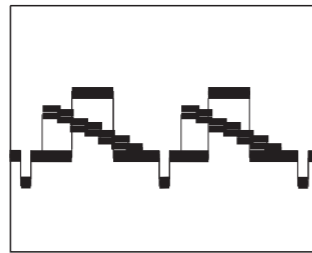

550 mVp-p (H)

⑩ IC200 ⑳ REC/PB

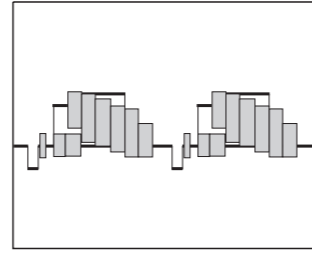

2 Vp-p (H)

⑮ IC200 ⑥⑩ REC/PB

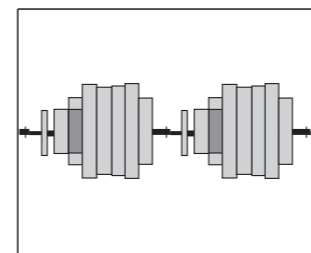

270 mVp-p (H)

③ IC200 ① PB

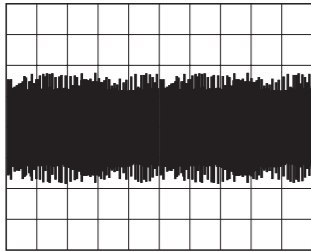

660 mVp-p (H)

⑦ IC200 ⑩ REC

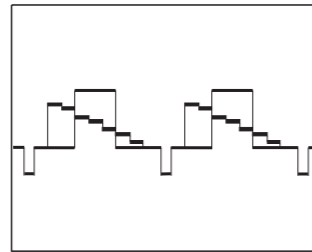

500 mVp-p (H)

⑪ IC200 ⑳ REC/PB

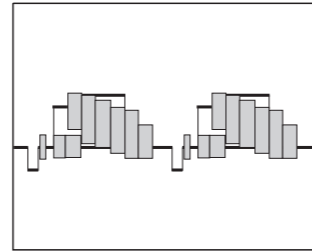

710 mVp-p (H)

⑯ IC200 ⑥⑩ REC

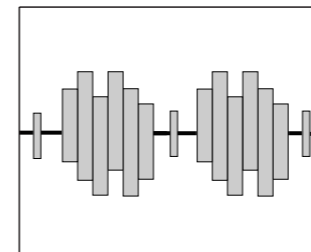

310 mVp-p (H)

④ IC200 ② REC

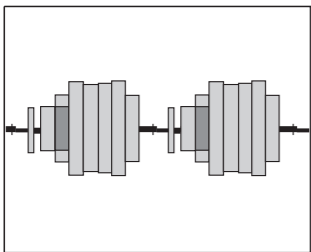

280 mVp-p (H)

⑦ IC200 ⑩ PB

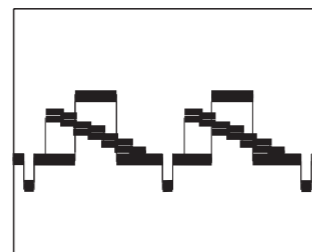

560 mVp-p (H)

⑫ IC200 ④② REC/PB

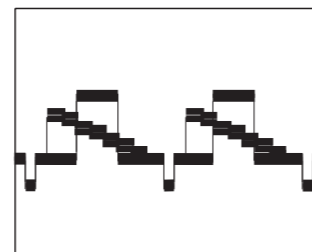

390 mVp-p (H)

⑯ IC200 ⑥⑩ PB

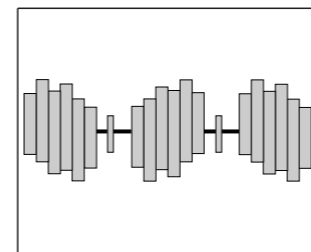

310 mVp-p (H)

⑤ IC200 ⑤ REC/PB

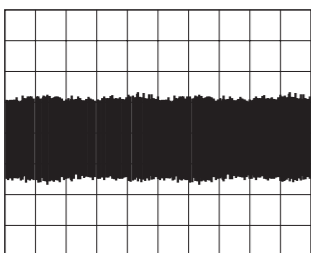

REC : 470 mVp-p (H)  
PB : 320 mVp-p (H)

⑧ IC200 ⑬ PB

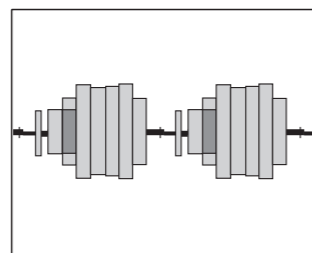

460 mVp-p (H)

⑬ IC200 ④④ REC/PB

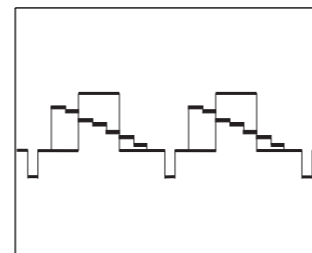

350 mVp-p (H)

⑰ IC200 ⑦⑩ REC/PB

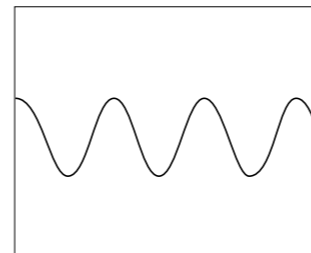

480 mVp-p (4.43 MHz)

MA-401 (SECAM) SCHEMATIC DIAGRAM • See page 4-5 for printed wiring board.

– Ref. No.: MA-401 board; 1,000 series –

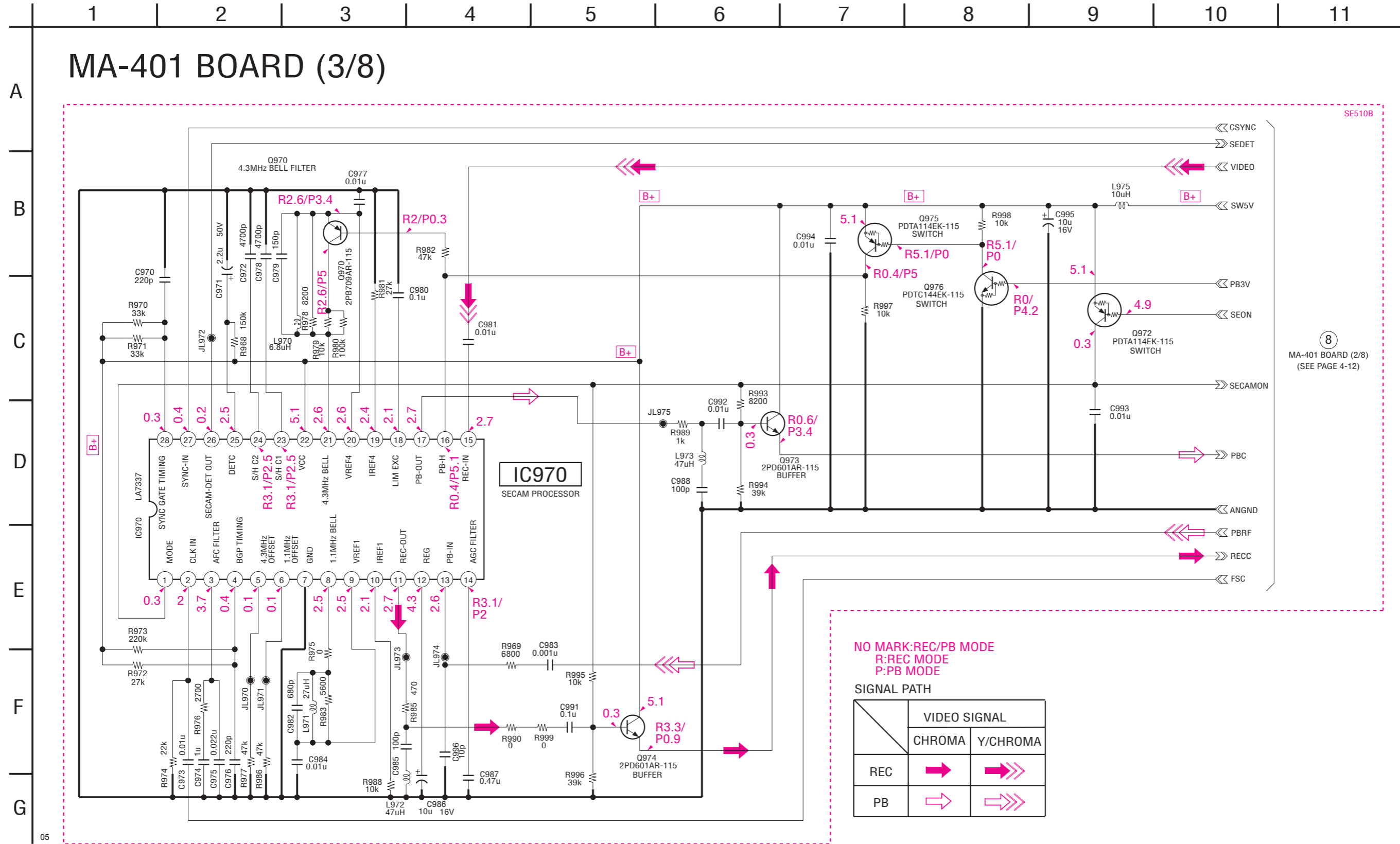

8  
MA-401 BOARD (2/8)  
(SEE PAGE 4-12)



MA-401 (SERVO/SYSTEM CONTROL) SCHEMATIC DIAGRAM • See page 4-5 for printed wiring board and page 4-19 for waveforms.

– Ref. No.: MA-401 board; 1,000 series –

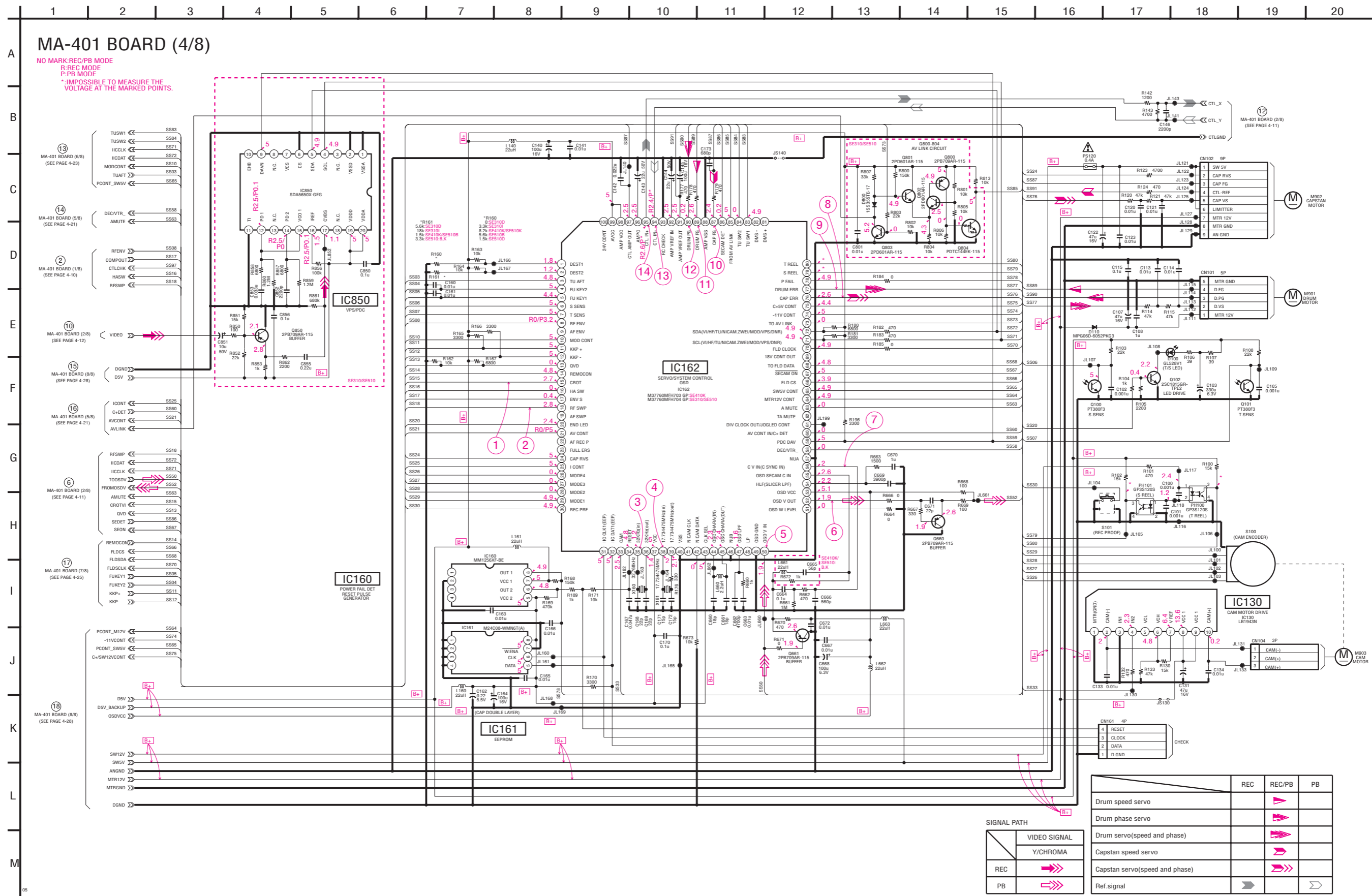

Note: The components identified by mark Δ or dotted line with mark Δ are critical for safety. Replace only with part number specified.

• Waveforms

1 IC162 15 REC/PB

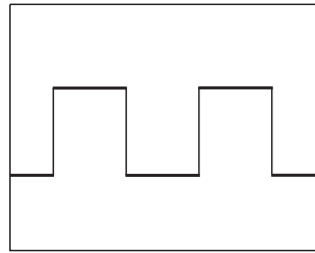

5.1 Vp-p (2 V)

2 IC162 18 REC/PB

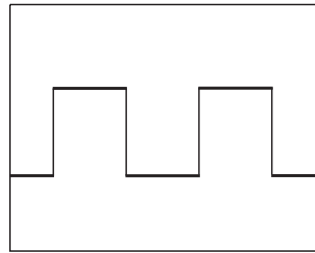

5.1 Vp-p (2 V)

3 IC162 35 REC/PB

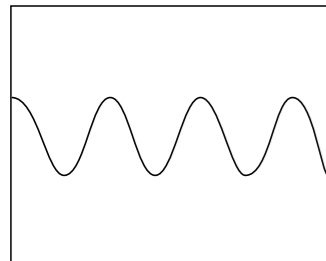

1.5 Vp-p (32.768 kHz)

4 IC162 38 REC/PB

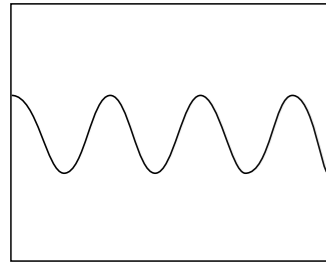

3.4 Vp-p (17.734475 MHz)

5 IC162 60 REC/PB

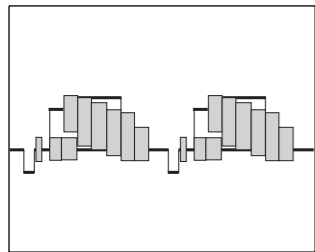

2 Vp-p (H)

6 IC162 52 REC/PB

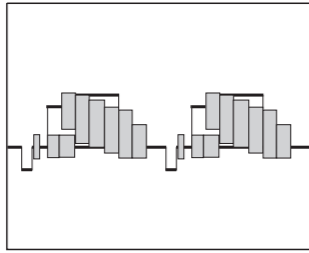

2 Vp-p (H)

7 IC162 56 REC/PB

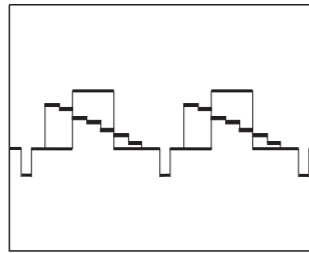

1.9 Vp-p (H)

8 IC162 76 REC/PB

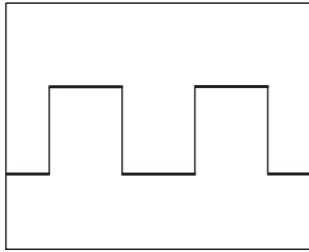

4.9 Vp-p (69 kHz)

9 IC162 77 REC/PB

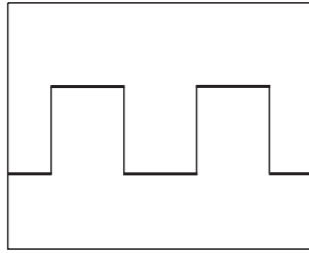

4.9 Vp-p (69 kHz)

10 IC162 87 REC/PB

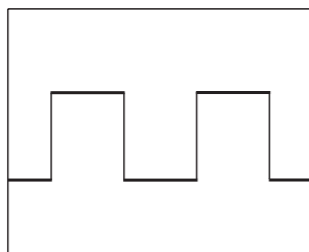

4.5 Vp-p (760 Hz)

11 IC162 89 REC/PB

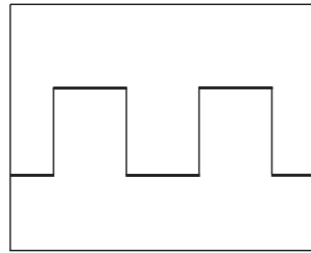

4.6 Vp-p (300 Hz)

12 IC162 90 REC/PB

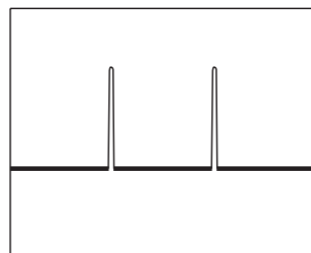

4.7 Vp-p (2 V)

13 IC162 94 REC

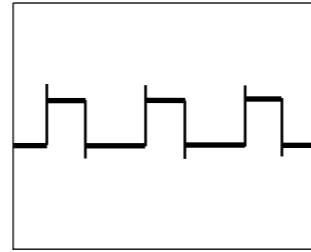

5.1 Vp-p (2 V)

14 IC162 95 REC

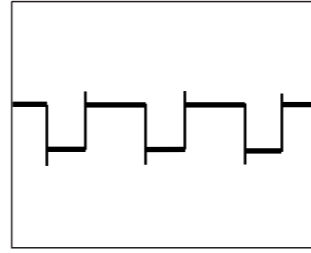

5.1 Vp-p (2 V)

**MA-401 (I/O) SCHEMATIC DIAGRAM • See page 4-5 for printed wiring board.**  
 – Ref. No.: MA-401 board; 1,000 series –

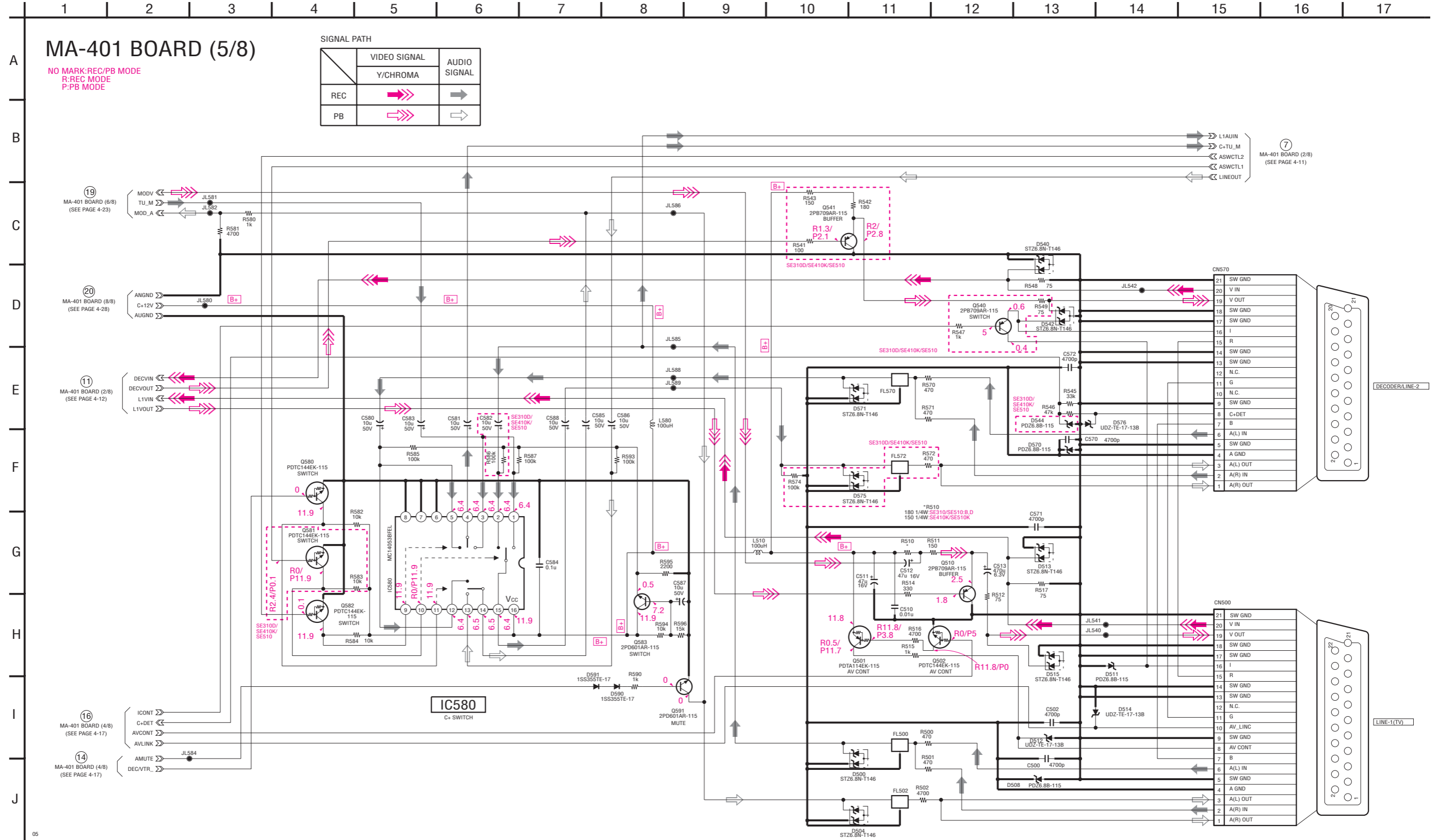

MA-401 (TUNER) SCHEMATIC DIAGRAM • See page 4-5 for printed wiring board.

– Ref. No.: MA-401 board; 1,000 series –

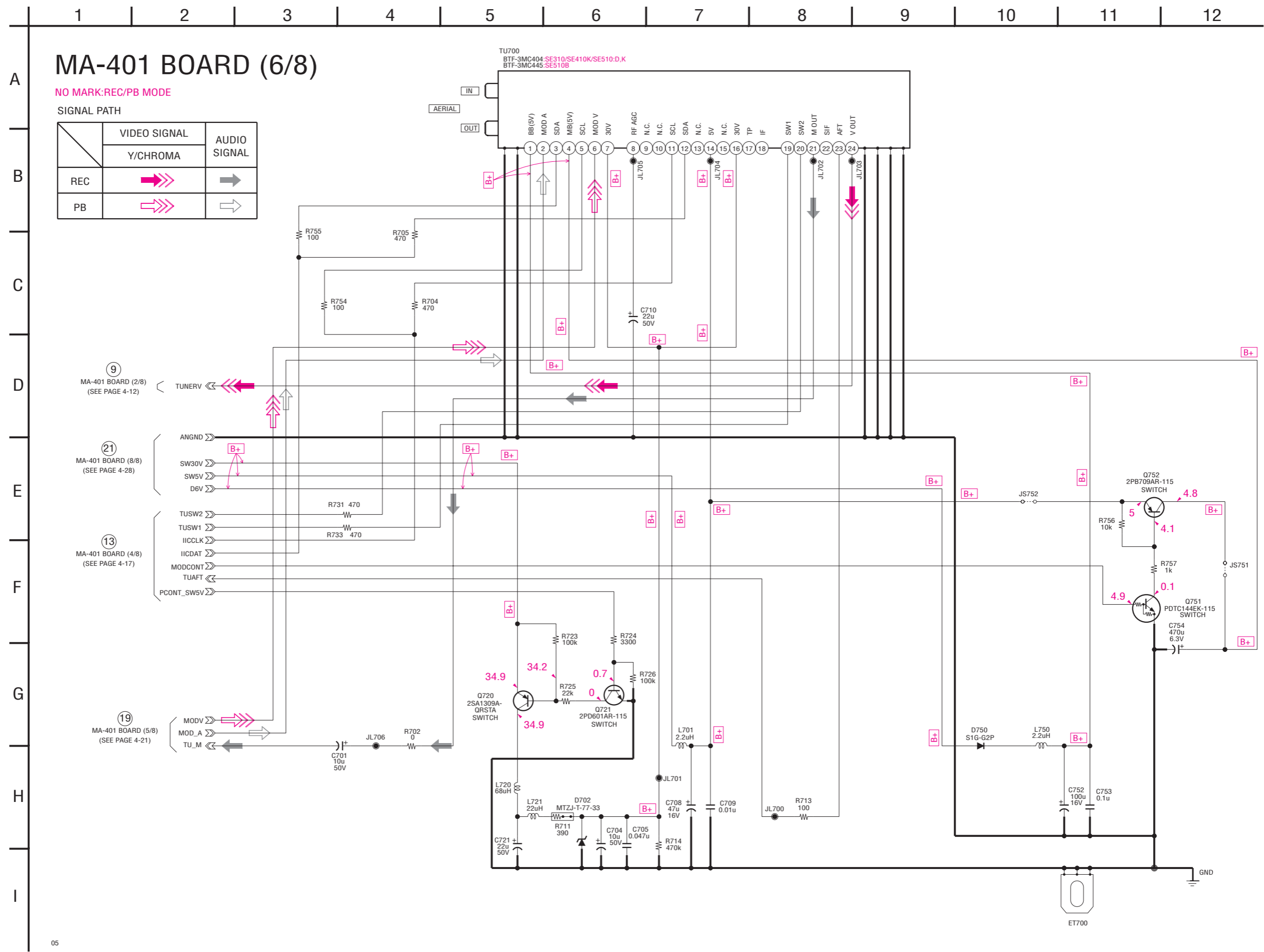

05

MA-401 (MODE CONTROL) SCHEMATIC DIAGRAM • See page 4-5 for printed wiring board.

- Ref. No.: MA-401 board; 1,000 series -

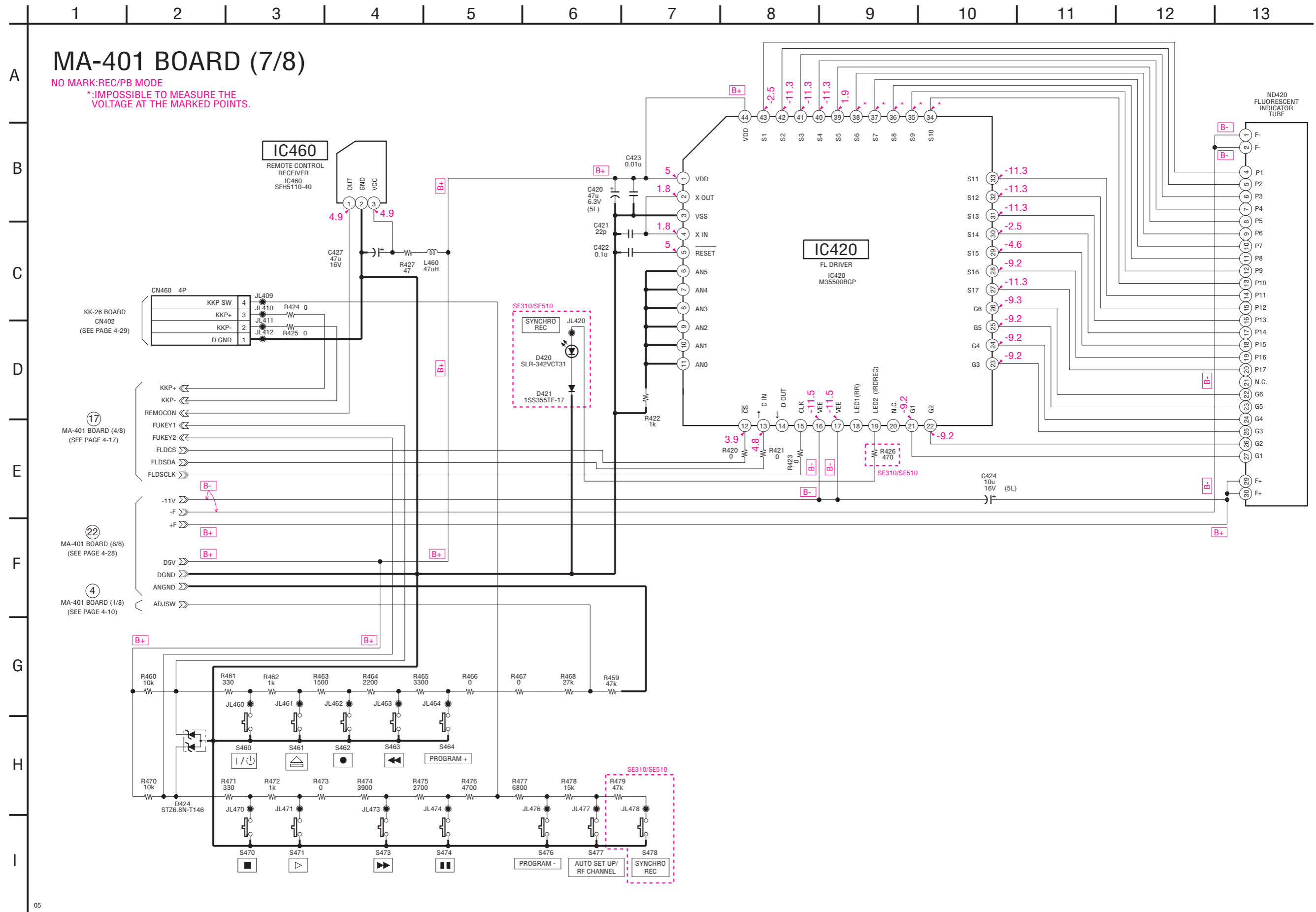

MA-401 (POWER SUPPLY) SCHEMATIC DIAGRAM • See page 4-5 for printed wiring board.

– Ref. No.: MA-401 board; 1,000 series –

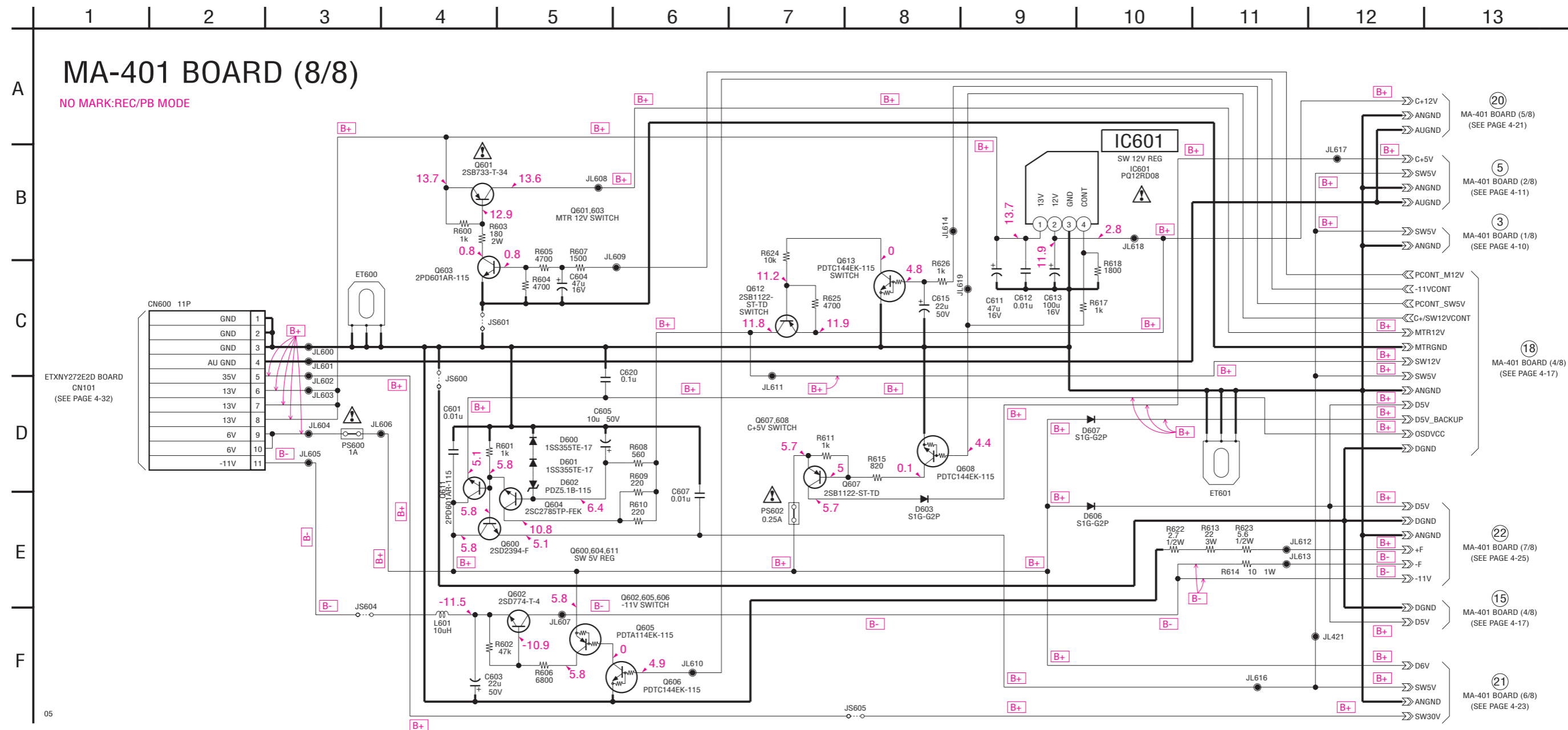

**Note:** The components identified by mark  $\triangle$  or dotted line with mark  $\triangle$  are critical for safety. Replace only with part number specified.

**KK-26 (DIAL TIMER) SCHEMATIC DIAGRAM AND PRINTED WIRING BOARD**

– Ref. No.: KK-26 board; 1,000 series –

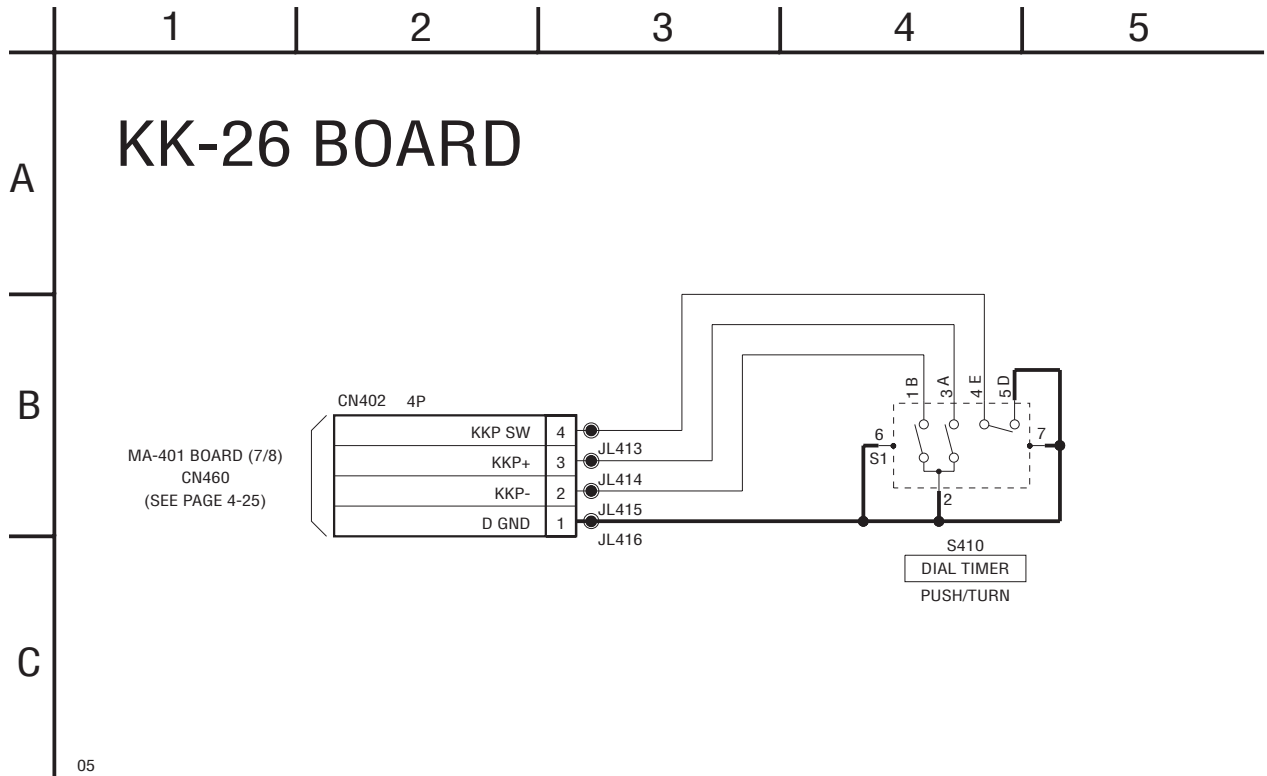

There are a few cases that the part isn't mounted in this model is printed on this diagram.

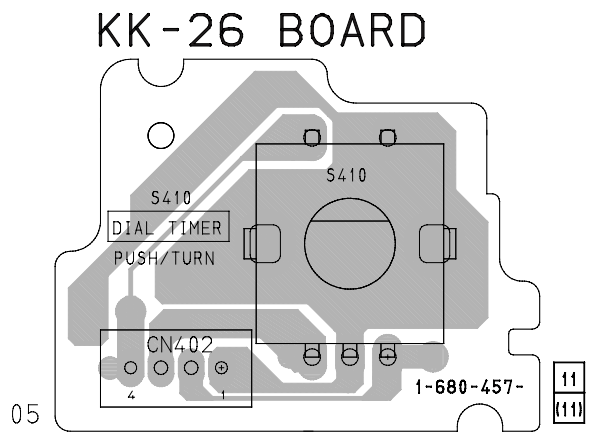

MA-401  
(VIDEO, AUDIO, I/O,  
SERVO/SYSTEM CONTROL,  
TUNER, MODE CONTROL)

POWER BLOCK  
(ETXNY272E2D)  
(POWER SUPPLY)

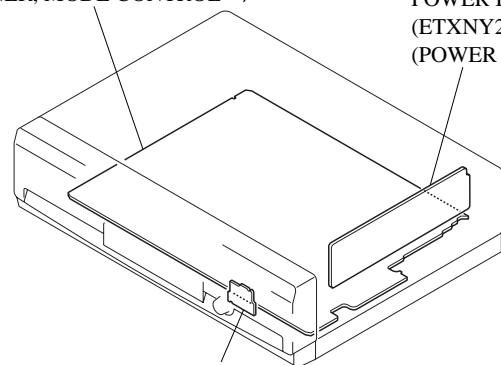

KK-26  
(DIAL TIMER)

**DIAL TIMER  
KK-26**

ETXNY272E2D (POWER SUPPLY) PRINTED WIRING BOARD

– Ref. No.: ETXNY272E2D board; 2,000 series –

There are a few cases that the part isn't mounted in this model is printed on this diagram.

ETXNY272E2D BOARD

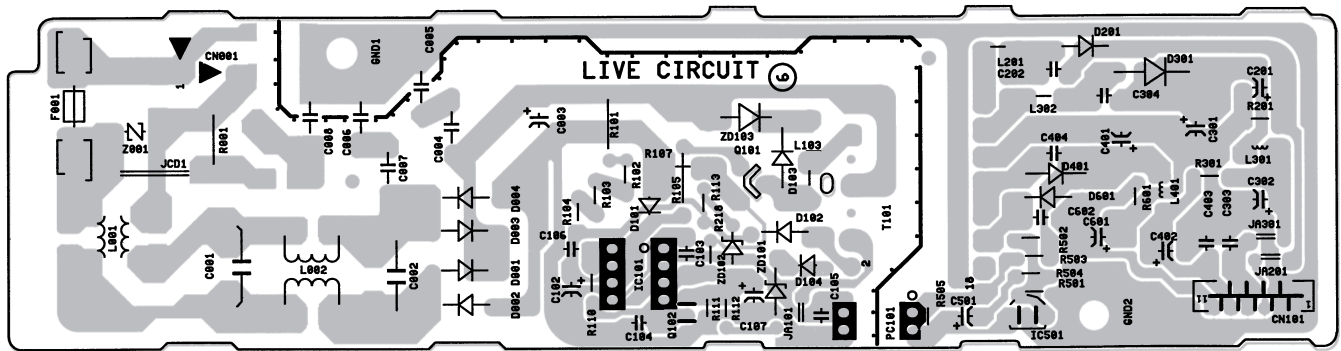

MA-401  
(VIDEO, AUDIO, I/O,  
SERVO/SYSTEM CONTROL,  
TUNER, MODE CONTROL)

POWER BLOCK  
(ETXNY272E2D)  
(POWER SUPPLY)

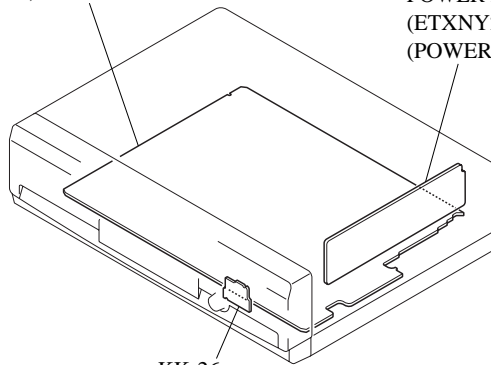

KK-26  
(DIAL TIMER)



ETXNY272E2D (POWER SUPPLY) PRINTED WIRING BOARD

- Ref. No.: ETXNY272E2D board; 2,000 series -

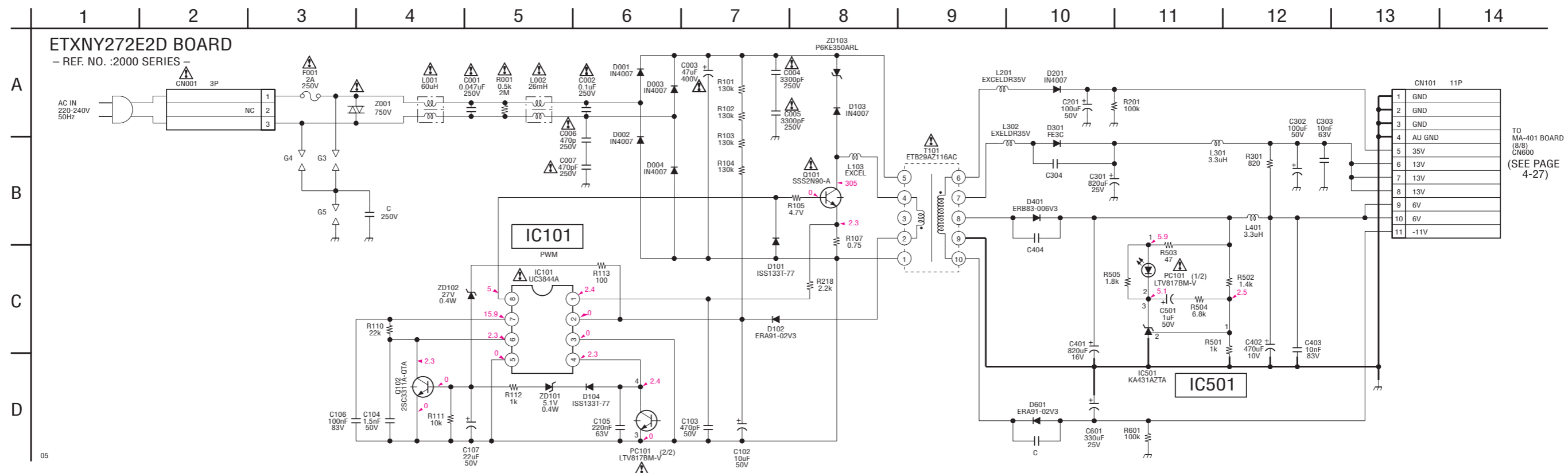

TO MA-401 BOARD (3/8) CN600 (SEE PAGE 4-27)

**Note:** The components identified by mark  $\Delta$  or dotted line with mark  $\triangle$  are critical for safety. Replace only with part number specified.

## SECTION 5 INTERFACE, IC PIN FUNCTION DESCRIPTION

### 5-1. SYSTEM CONTROL — VIDEO/RP BLOCK INTERFACE (MA-401 BOARD IC162)

Signal	Pin No.	I/O	STOP/ FF/REW	TAPE LOADING	TAPE UNLOADING	PB	REC	REC/PAUSE
RF SWP	MA-401 IC162 ⑮	O	*1	*1	*1	*1	*1	*1
QVD	MA-401 IC162 ⑬	O	L	L	L	*2	L	L
C.V.IN	MA-401 IC162 ⑤⑥	I	*3	*3	*3	*3	*3	*3

\*1 Synchronized with drum rotation. 25 Hz 50% duty pluse.

\*2 Normally "L". "H" when video signal is not generated.

\*3 Composite sync signal (positive).

### 5-2. SYSTEM CONTROL — SERVO PERIPHERAL CIRCUIT INTERFACE (MA-401 BOARD IC162)

Signal	Pin No.	I/O	STOP	FF	REW	TAPE LOADING	TAPE UNLOADING	PB	REC
CTL +IN	MA-401 IC162 ⑨⑤	I/O	*7	*7	*7	*7	*7	*7	*1
DRUM PG	MA-401 IC162 ⑩⑩	I	*3	*3	*3	*3	*3	*3	*3
DRUM FG	MA-401 IC162 ⑧⑨	I	*4	*4	*4	*4	*4	*4	*4
CAP FG	MA-401 IC162 ⑧⑦	I	H/L	*2	*2	*5	*5	*2	*2
CAP RVS	MA-401 IC162 ②④	O	H/L	L	H	L	H	L	L
CAP ERR	MA-401 IC162 ⑦⑥	O	L	*6	*6	*6	*6	*6	*6
DRUM ERR	MA-401 IC162 ⑦⑦	O	*6	*6	*6	*6	*6	*6	*6

\*1. 25 Hz pulse.

\*2. Pulse in period in proportion to tape speed.

\*3. 25 Hz "H" pulse.

\*4. 330 Hz pulse.

\*5. Unstable period pulse.

\*6. DC voltage 1 to 5V.

\*7. Hi-Z (2.5 V)

### 5-3. SYSTEM CONTROL — MECHANISM BLOCK INTERFACE (MA-401 BOARD IC162)

Signal	Pin No.	I/O	EJECTED	CASSETTE LOADING	CASSETTE UNLOADING	TAPE THREADING	TAPE UNTHREADING	STOP	FF	REW	PB	REC
CAM	MA-401 IC162 ⑳	O	M	H/M	L/M	H/M	L/M	M	M	M	M	M
MODE 1	MA-401 IC162 ㉑	I	H	—	—	L	L	H	H	H	H	H
MODE 2	MA-401 IC162 ㉒	I	H	—	—	L	L	H	H	H	L	L
MODE 3	MA-401 IC162 ㉓	I	L	—	—	H	H	H	L	L	L	L
MODE 4	MA-401 IC162 ㉔	I	L	—	—	H	H	L	H	H	L	L
REC PRF	MA-401 IC162 ㉕	I	L	*1	*1	*1	*1	*1	*1	*1	*1	*1
T REEL	MA-401 IC162 ㉖	I	H/L	H/L	H/L	H/L	H/L	H/L	*2	*2	*2	*2
S REEL	MA-401 IC162 ㉗	I	H/L	H/L	H/L	*2	*2	H/L	*2	*2	*2	*2
END LED	MA-401 IC162 ㉘	O	L	*3	*3	*3	*3	*3	*3	*3	*3	*3
T SENS	MA-401 IC162 ㉙	I	*3	*3	*3	*4	*4	*4	*4	*4	*4	*4
S SENS	MA-401 IC162 ㉚	I	*3	*3	*3	*4	*4	*4	*4	*4	*4	*4

\*1. "L" when erasing protection tab is bent. "H" when not bent.

\*2. Pulse of period in proportion to reel rotating speed.

\*3. Approx. 2 msec period "H" pulse.

\*4. Normally "L". 2 msec period "H" pulse when tape top or tape end is detected.

\*5. Hi-Z

### 5-4. SYSTEM CONTROL — SYSTEM CONTROL PERIPHERAL CIRCUIT INTERFACE (MA-401 BOARD IC162)

Signal	Pin No.	I/O	I/O level
RESET	MA-401 IC162 ㉛	I	Normal "H", "L" when service Interruption is detected or restored.

### 5-5. SYSTEM CONTROL — AUDIO BLOCK INTERFACE (MA-401 BOARD IC162)

Signal	Pin No.	I/O	STOP/ FF/REW	TAPE LOADING	TAPE UNLOADING	PB	REC	REC/PAUSE
A MUTE	MA-401 IC162 ㉜	O	L	L	L	L	L	H

## 5-6. SERVO/SYSTEM CONTROL MICROPROCESSOR PIN FUNCTIONS (MA-401 BOARD IC162)

Pin No.	Pin Name	I/O	Function
1	DEST1	I	Destination identification input 1
2	DEST2	I	Destination identification input 2
3	TU AFT	I	AFT input from TUNER for station selection
4	FU KEY2	I	Function key input (9 keys)
5	FU KEY1	I	Function key input (9 keys)
6	S SENS	I	Tape end sensor input
7	T SENS	I	Tape top sensor input
8	RF ENV	I	Video RF envelope input
9	N.C.	—	N.C.
10	MOD CONT	O	RF modulator ON/OFF control
11	KKP+	I	KKP 2-phase pulse B input
12	KKP-	I	KKP 2-phase pulse A input
13	QVD	O	Pseudo VD output
14	REMOCON	I	Remote control SIRCS signal input
15	CROT	O	Head azimuth information
16	HA SW	O	SP/EP head switching signal
17	ENV S	I	Identification signal of SP/EP head output comparison & detection
18	RF SWP	O	Video RF switching pulse output
19	AF SWP	O	N.C.
20	END LED	O	End sensor LED output
21	AV CONT	O	EURO 21 pin AV CONT signal output
22	AF REC P	O	N.C.
23	FULL ERS	O	N.C.
24	CAP RVS	O	Inverted capstan signal
25	I CONT	O	EURO 21 pin-I CONT signal output
26	MODE 4	I	Cam encode data 4
27	MODE 3	I	Cam encode data 3
28	MODE 2	I	Cam encode data 2
29	MODE 1	I	Cam encode data 1
30	REC PRF	I	Safety tab detection input
31	IIC CLK1 (EEP)	O	I2C clock (EEPROM control)
32	IIC DATA1 (EEP)	I/O	I2C data (EEPROM control)
33	CAM	O	Cam motor control signal
34	RESET	I	Reset input
35	32kHz (IN)	I	Sub clock input
36	32kHz (OUT)	O	Sub clock output
37	Vcc	—	Power supply input terminal (high speed mode: 4.0 to 5.5 V, low speed mode: 2.6 to 5.5 V)
38	17.734475MHz (IN)	I	Main clock input
39	17.734475MHz (OUT)	O	Main clock output
40	Vss	—	Ground terminal
41	NICAM. CLK	O	N.C.
42	NICAM. DATA	O	N.C.
43	CLK SEL	I	Selection of oscillation clock when reset is canceled. L: sub clock, H: main & sub clocks
44	OSC CHARA (IN)	I/O	Clock input for OSD character size
45	OSC CHARA (OUT)	I/O	Clock output for OSD character size
46	NUB	—	Connected to Ground
47	OSD LPF	I/O	External filter that doubles the fsc, is connected to this terminal
48	LP	O	“L” at SP. “H” at EP/LP.
49	OSD GND	—	Ground terminal of OSD/slicer
50	OSD V IN	I	Video signal input for OSD overlay

Pin No.	Pin Name	I/O	Function
51	OSD W LEVEL	I	OSD white level input
52	OSD V OUT	O	OSD video signal output
53	OSD Vcc	–	Power supply input terminal for OSD/slicer (4.75 V to 5.25 V)
54	HLF (SLICER LPF)	I/O	LPF connection terminal for slicer/AFC (This terminal is used as the HLF terminal when C. Video is input to pin-56.)
55	OSD SECAM C IN	I	Color signal input for SECAM OSD
56	C V IN (C SYNC IN)	I	Video signal input for tuner's station selection, OSD and servo sync signal detection (after passing filter)
57	NUA	–	Connected to Ground
58	DEC/VTR	O	Decoder/VTR switching
59	PDC DAV	I	PDC/VPS signal reception identification input
60	AV CONT IN/C+DET	I	CANAL+ connection identification input
61	DIV CLK OUT/JOGL LED CONT	O	Terminal of using JOGL LED output or adjustment mode output of clock dividing frequency
62	TA MUTE	O	Tuner audio mute signal output
63	A MUTE	O	Audio mute signal output
64	MTR 12V CONT.	O	Motor 12 V power control signal
65	SW 5V CONT.	O	SW 5 V power control signal
66	FLD CS	O	Chip selection signal for display tube driver
67	SECAM ON	O	SECAM ON signal/surround audio control (switched by destination)
68	TO FLD DATA	O	Serial data out CH0 (FLD)
69	18V CONT	O	N.C.
70	FLD CLOCK	O	Serial clock CH0 (FLD)
71	SCL (VI/HF/TU/NICAM ZWEI/MOD/VPS/DNR)	I/O	I2C clock (video/HiFi/tuner/ARC/modulator/VPS control)
72	SDA (VI/HF/TU/NICAM ZWEI/MOD/VPS/DNR)	I/O	I2C data (video/HiFi/tuner/ARC/modulator/VPS control)
73	TO AV LINK	O	SMART LINK data output for communication
74	–14V CONT	O	Power save control
75	C+ 5V CONT	O	Power save control
76	CAP ERROR	O	Capstan error output
77	DRUM ERROR	O	Drum error output
78	P FAIL	I	Power failure detection input
79	S REEL	I	Supply reel sensor input
80	T REEL	I	Take up reel sensor input
81	DMS+	I	N.C.
82	DMS–	I	N.C.
83	TU SW1	O	Turner system BG/L selection signal
84	TU SW2	O	Turner system BGL/L selection signal
85	FROM AV LINK	I	SMART LINK data input for communication
86	SECAM DET	I	SECAM identification input
87	CAP FG	I	Capstan FG input
88	AMP Vss	–	Ground terminal for analog amplifier (connected to Vss)
89	DRUM FG	I	Drum FG input
90	DRUM PG	I	Drum PG input
91	AMP VREF OUT	–	Analog amplifier reference power supply output terminal
92	AMP VREF IN	–	Analog amplifier reference power supply output terminal
93	RC CHECK	I	No use (Fix to "L" on the outside for the terminal only for the input)
94	CTL –IN	I/O	CTL signal input/output terminal
95	CTL +IN	I/O	CTL signal input/output terminal
96	AMP C	–	CTL amplifier AC Ground terminal
97	CTL AMP OUT	O	CTL amplifier output
98	AMP Vcc	–	Power supply input terminal for analog amplifier (connected to Vcc)
99	AVcc	–	Power supply input and reference voltage input to A-D converter
100	24V CONT	O	N.C.

## 5-7. MODE CONTROL PIN FUNCTIONS (MA-401 BOARD IC420)

Pin No.	Pin Name	I/O	Function
1	VDD	–	D5V
2	X OUT	O	X' tal out
3	VSS	–	Ground.
4	X IN	I	X' tal in
5	$\overline{\text{RESET}}$	I	RESET input.
6	AN5	–	Ground.
7	AN4	–	Ground.
8	AN3	–	Ground.
9	AN2	–	Ground.
10	AN1	–	Ground.
11	AN0	–	Ground.
12	$\overline{\text{CS}}$	I	FLD chip select signal input.
13	D IN	I	FLD IIC BUS (data) input.
14	D OUT	O	Not connect.
15	CLK	O	FLD clock.
16	VEE	–	–11V
17	VEE	–	–11V
18	LED1 (RR)	O	RR LED control signal output.
19	LED2 (IRDREC)	O	IRDREC LED control signal output.
20	NC	–	Not Connect.
21	G1	O	Grid terminal 1.
22	G2	O	Grid terminal 2.
23	G3	O	Grid terminal 3.
24	G4	O	Grid terminal 4.
25	G5	O	Grid terminal 5.
26	G6	O	Grid terminal 6.
27	S17	O	Segment terminal 17.
28	S16	O	Segment terminal 16.
29	S15	O	Segment terminal 15.
30	S14	O	Segment terminal 14.
31	S13	O	Segment terminal 13.
32	S12	O	Segment terminal 12.
33	S11	O	Segment terminal 11.
34	S10	O	Segment terminal 10.
35	S9	O	Segment terminal 9.
36	S8	O	Segment terminal 8.
37	S7	O	Segment terminal 7.
38	S6	O	Segment terminal 6.
39	S5	O	Segment terminal 5.
40	S4	O	Segment terminal 4.
41	S3	O	Segment terminal 3.
42	S2	O	Segment terminal 2.
43	S1	O	Segment terminal 1.
44	VDD	–	D5V

## SECTION 6 ERROR CODES

### 6-1. ERROR CODE INDICATION

- Error codes are indicated using the lower 5 digits in the fluorescent display tube.  
“At this time, Colon “:”between character is not indicated.”

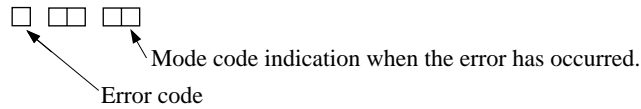

#### ERROR CODE

0	No error
1	Cam encoder error Loading direction
2	Cam encoder error Unloading direction
3	T reel error
4	S reel error
5	Capstan error
6	Drum error
7	Error on initializing
8	Cassette loading error
9	Reserve

#### MODE CODE

0	Power-on eject	10	FWD x1	20	REW play
1	Power-on initial	11	FWD x2	21	Cas. loading
2	Power-off elect	12	CUE	22	Tape loading
3	Power-off stop	13	PB-pause	23	Power-off loading
4	FF	14	RVS-pause	24	Mecha. error (Power on)
5	REW	15	RVS x1	25	Power-on eject initial
6	REC	16	RVS x2	26	Power-off eject initial
7	REC-pause	17	REV	27	APC REC
8	Power-on stop	18	Power-off initial	28	Cas. loading
9	PB	19	Mecha. error (Power off)		(No auto PB check)

## SECTION 7 ADJUSTMENTS

### 7-1. MECHANICAL ADJUSTMENTS

For the mechanical adjustments, please refer to the "VHS MECHANICAL ADJUSTMENT MANUAL VI (S MECHANISM)" (9-921-647-11).

### 7-2. ELECTRICAL ADJUSTMENTS

See the adjusting part location diagram from on page 7-4 for the adjustment.

#### 2-1. PREPARATION BEFORE ADJUSTMENTS

##### 2-1-1. Equipment Required

The measuring instruments used for this alignment include:

- 1) Monitor TV
- 2) Oscilloscope, dual-trace, bandwidth of 30 MHz or more, with delay mode (A probe 10:1 should be used unless otherwise specified.)
- 3) Frequency counter
- 4) PAL Pattern generator
- 5) Remote commander
- 6) Digital voltmeter
- 7) Audio generator
- 8) Audio level meter
- 9) Audio attenuator
- 10) Alignment tapes  
KRV-51P (PAL) Part No. : 8-192-955-57

##### 2-1-2. Equipment Connection

Unless otherwise specified, connect and adjust the measuring instruments as shown in the following diagram.

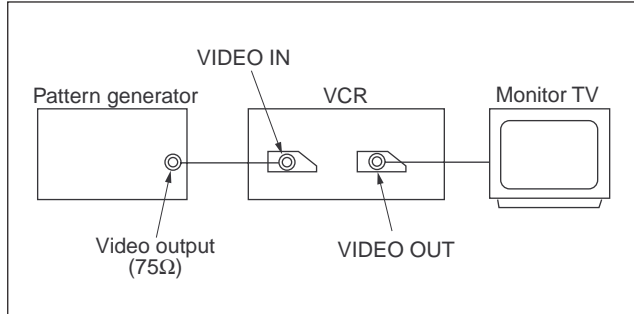

**Fig. 7-2-1**

##### 2-1-3. Set-up of Adjustment

In this adjustment, PAL pattern generator is connected with LINE-2 input terminal. When check to tuner, connected AERIAL terminal. Check that the synchronizing signal of the Y signal has an amplitude of approximately 0.7 V and that the red signal has an amplitude of approximately 0.3 V and its waveform is flat. And check that the level ratio of burst signal to "red" signal is 0.30 : 0.66. The video signal (color bar) used for electrical aligning this unit is shown in Fig. 6-2-2.

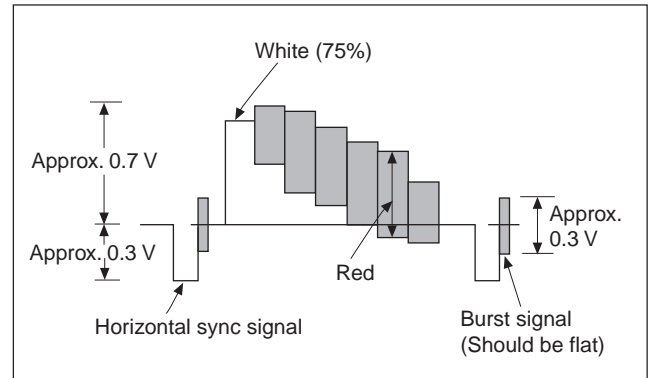

**Fig. 7-2-2 Color Bar Signals of Pattern Generator**

##### 2-1-4. Alignment Tape

• Contents of KRV-51P

	Mode	Period	Video signal	Audio signal	
				Hi-Fi	Normal
1	SP	7 minutes	Color bar	400Hz (L/R)	400Hz
2		3 minutes	Monoscope		
3	LP	7 minutes	Color bar		
4		3 minutes	Monoscope		



### 2-1-5. Input/Output Levels and Impedance

Video input: LINE-1 (TV)/LINE-2 IN

Input signal: 1 V<sub>p-p</sub>, 75 ohms, unbalanced, sync negative

Video output: LINE-1 (TV)

Output signal: 1 V<sub>p-p</sub>, 75 ohms, unbalanced, sync negative

Audio input: LINE-1 (TV)/LINE-2 IN

Input level: -7.5 dBs  
(0 dBs= 0.775 V<sub>rms</sub>)

Input impedance: more than 47 kilohms

Audio output: LINE-1 (TV)

Standard level: -7.5 dBs at load impedance 47 kilohms

Output impedance: less than 10 kilohms

### 2-1-6. Adjustment Sequence

The adjustments should be performed in the following sequence.

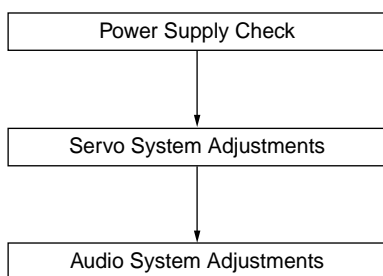

## 2-2. POWER SUPPLY CHECK

### 2-2-1. Output Voltage Check (MA-401 Board)

Mode	STANDBY
D5 V Check	
Measurement point	Cathode of D606
Specified value	4.8 to 5.4 V

Mode	E-E
-11 V Check	
Measurement point	Corrector of Q602
Specified value	-13.5 to -9.5 V
SW +12 V Check	
Measurement point	IC601 pin ② or corrector of Q612
Specified value	11.7 to 12.3 V
SW +5 V Check	
Measurement point	Emitter of Q600
Specified value	4.8 to 5.4 V
MTR12 V Check	
Measurement point	Corrector of Q601
Specified value	12.6 to 13.6 V
SW +30 V Check	
Measurement point	Corrector of Q720
Specified value	33.5 to 36.5 V

#### [Check Method]

- 1) Each of these supply voltages must meet its specified value.

## 2-3. SERVO SYSTEM CHECK

### 2-3-1. RF Switching Position Adjustment (MA-401 Board)

#### [Adjustment Purpose]

To adjust the link of the A-ch and B-ch of the tape playback outputs.

To make the unit compatible with other tapes and units. If this specification is not satisfied, the link will appear on the screen and the screen will be disrupted, etc.

Mode	Playback
Signal	Alignment tape: SP color bar portion
Measurement point	CH1: CN262 pin ① (PB RF) CH2: CN262 pin ② (RF SWP)
Measuring instrument	Oscilloscope
Adjusting element	Remote commander CH+/-
Specified value	A=minimize

#### [Adjustment Method]

- 1) Playback the alignment tape.
- 2) Short CN262 pin ⑤ to Ground.
- 3) Check that "A P" is indicated on FL display.
- 4) Adjust so that part A becomes minimized at CH +/-.
- 5) Write data in EEPROM by pressing PAUSE button.
- 6) The display "A P" disappears and then the Adjustment mode terminates.

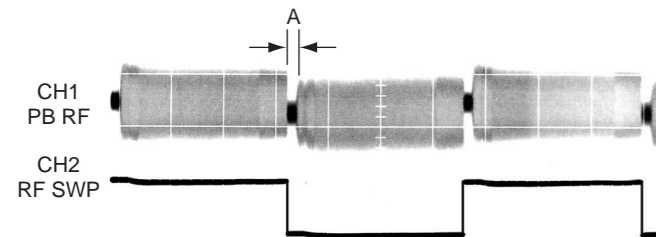

Fig. 7-2-3

## 2-4. AUDIO SYSTEM ADJUSTMENTS

### [Connecting Instruments]

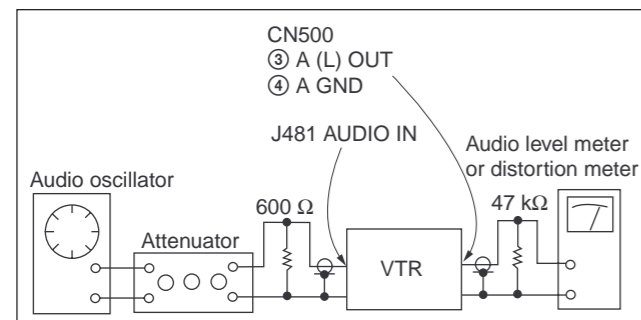

Fig. 7-2-4

### 2-4-1. Normal Audio System Adjustment

- Make adjustment in the SP mode unless otherwise specified. Use a normal VHS cassette for an adjustment tape.
- Set AUDIO MONITOR to normal.

### 2-4-2. ACE Head Adjustment

Refer to the VHS mechanical adjustment manual VI (S MECHANISM) (9-921-647-11).

### 2-4-3. E-E Output Level Check

#### [Adjustment purpose]

Confirm that the output level adjust the reference input is within the specification.

Mode	E-E
Signal	400 Hz, -6.3 dBs
Measurement point	CN500 Pin ③
Measuring instrument	Audio level meter
Specified value	-6.3 ± 2 dBs

#### [Check Method]

- 1) Input signal of 400 Hz and -6.3 dBs to the J480.
- 2) Check that the audio output level is -6.3 ± 2 dBs.

### 2-4-4. Frequency Response Check

#### [Adjustment purpose]

Confirm that the frequency characteristic is within the specification.

Mode	REC and PB (SP mode)
Signal	400 Hz, -26.3 dBs 7 kHz, -26.3 dBs
Measurement point	CN500 Pin ③
Measuring instrument	Audio level meter
Specified value	0 ± 3 dB

**Note:** Tape path adjustment must have been completed.

#### [Confirmation Method]

- 1) Supply a signal of 400 Hz, -26.3 dBs to J481 AUDIO IN.
- 2) Connect the audio level meter to CN500 Pin ③.
- 3) Adjust the attenuator so that the audio level meter will indicate -26.3 dBs.
- 4) Make recording in the SP mode.
- 5) Set an audio line input signal to 7 kHz and make recording.
- 6) Playback a recorded portion, and measure output levels at 400 Hz and 7 kHz.
- 7) Confirm that the 7 kHz playback output level within a range of the 400 Hz playback output level 0 dB to ± 3 dB.

## 2-5. ADJUSTING PARTS LOCATION DIAGRAM

### MA-401 BOARD (CONDUCTOR SIDE)

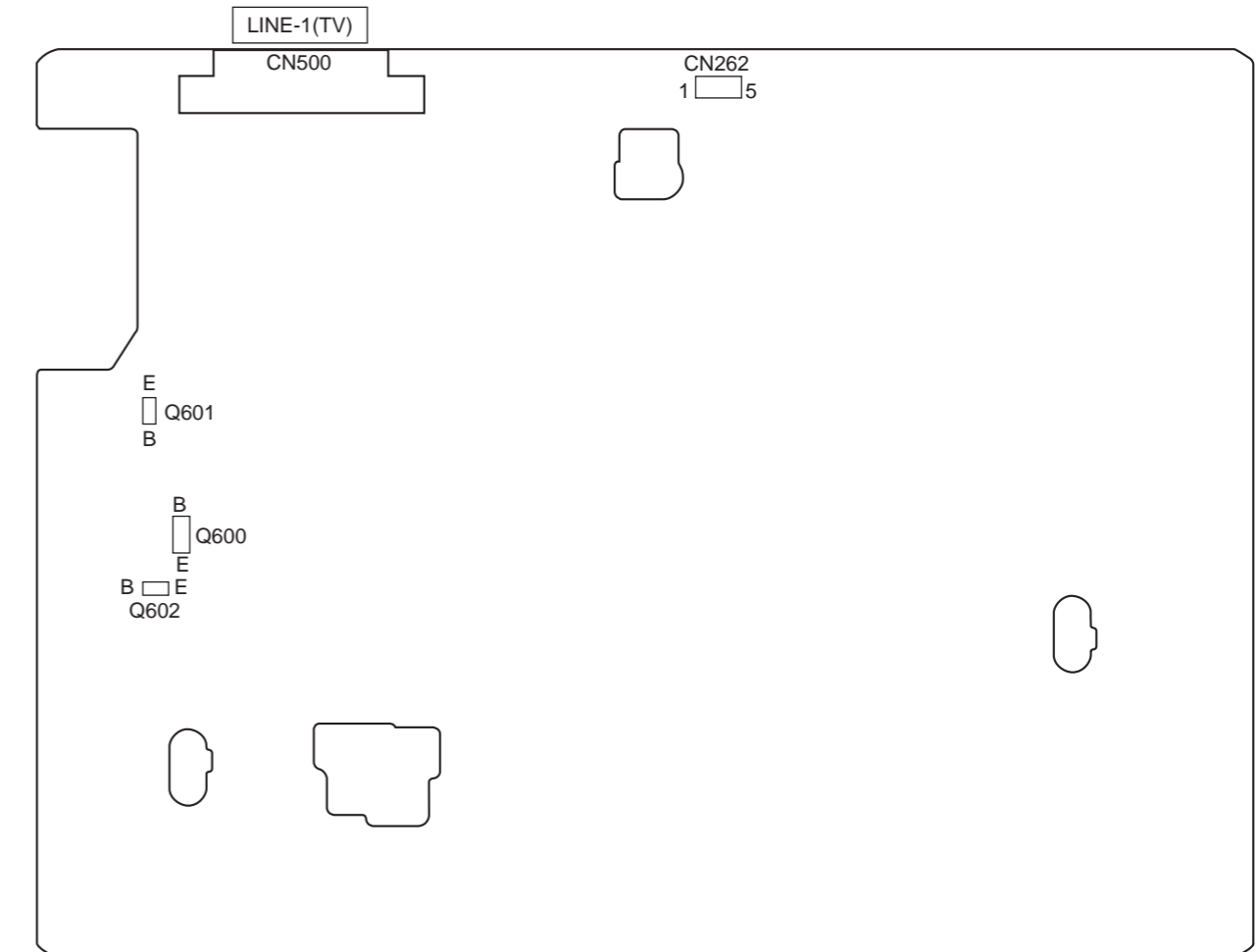



## 8-1-2. CHASSIS ASSEMBLY

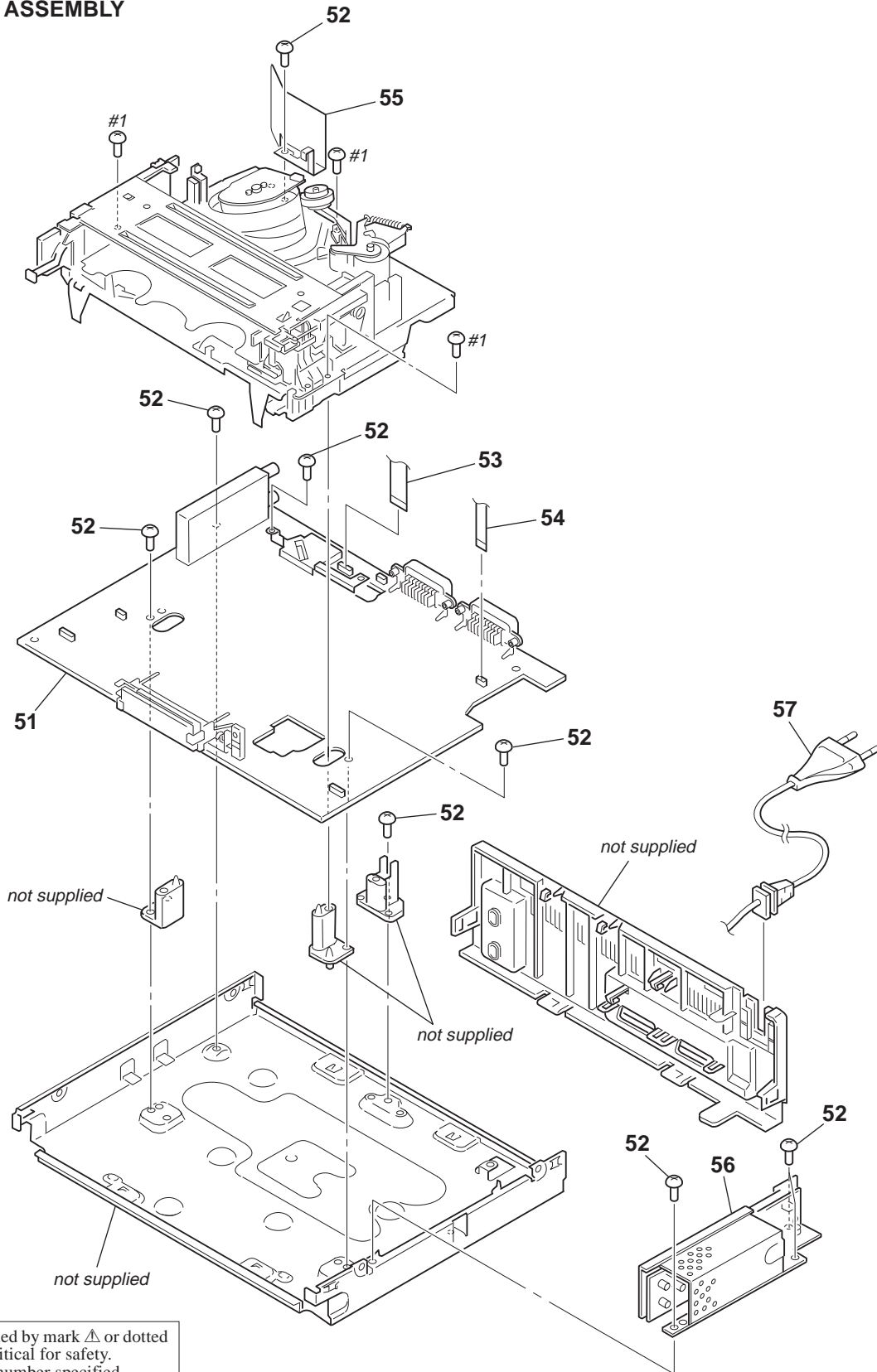

The components identified by mark  $\triangle$  or dotted line with mark  $\triangle$  are critical for safety. Replace only with part number specified.

Ref. No.	Part No.	Description	Remark	Ref. No.	Part No.	Description	Remark
* 51	A-6713-786-A	MA-401 BOARD, COMPLETE (SE510D)		52	3-970-608-21	SUMITITE (B3), +BV	
* 51	A-6713-787-A	MA-401 BOARD, COMPLETE (SE310D)		53	1-792-018-11	CABLE, FLAT (FAC-8)	
* 51	A-6713-789-A	MA-401 BOARD, COMPLETE (SE510B)		54	1-792-019-11	CABLE, FLAT (FFM-36)	
* 51	A-6713-790-A	MA-401 BOARD, COMPLETE (SE510K)		55	3-058-999-01	PLATE, DRUM COVER	
* 51	A-6713-791-A	MA-401 BOARD, COMPLETE (SE410)		* 56	1-468-459-11	POWER BLOCK (ETXNY272E2D)	
* 51	A-6713-792-A	MA-401 BOARD, COMPLETE (SE310I)		$\triangle$ 57	1-782-012-22	CORD, POWER	

### 8-1-3. MECHANISM CHASSIS ASSEMBLY (1)

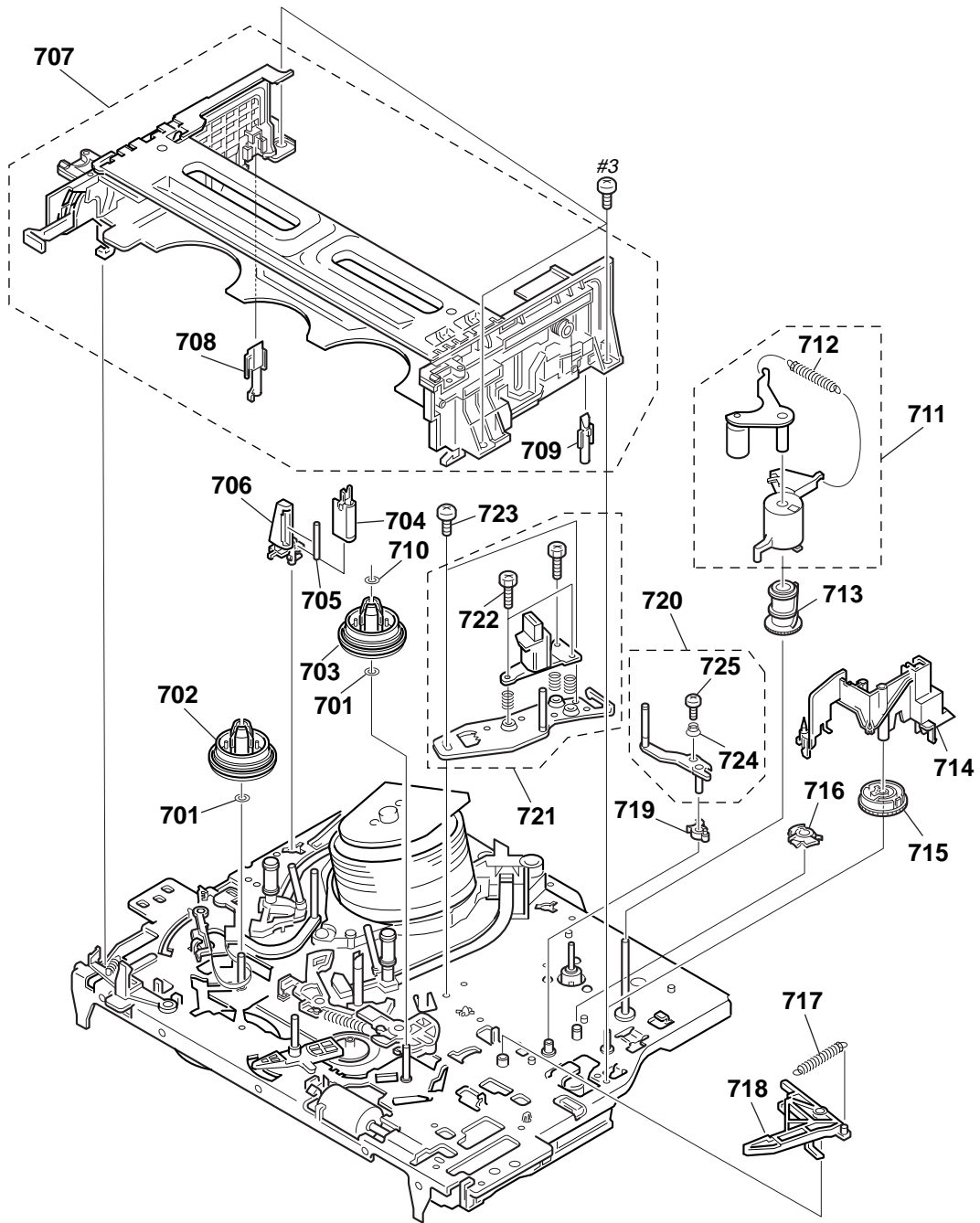

Ref. No.	Part No.	Description	Remark	Ref. No.	Part No.	Description	Remark
701	3-977-509-01	WASHER, THRUST		714	3-063-773-02	OPENER, LID (SL)	
702	3-977-507-01	TABLE, REEL (S)		715	3-977-441-03	GEAR, PINCH PRESSING	
703	3-977-508-01	TABLE, REEL (T)		716	3-977-445-02	GEAR, TG8 ARM DRIVING	
704	1-500-471-11	HEAD, FE		717	3-062-763-01	SPRING, EXTENSION (RVS BRAKE)	
705	3-977-495-01	SHAFT TG2		718	X-3950-964-1	ARM ASSY, RVS BRAKE (SL)	
706	3-977-494-01	HOLDER, FEH		719	3-063-756-01	GEAR, TG8 ARM H/R	
707	A-6776-359-C	FL COMPLETE ASSY (SL)		720	X-3947-590-1	TG8 ASSY	
708	3-977-535-01	PLATE, LUMINOUS (END SENSOR)		721	A-6775-791-A	ACE BLOCK ASSY (EURO 3)	
709	3-977-536-01	PLATE, LUMINOUS (TOP SENSOR)		722	3-974-556-11	+ HEXA TT 2.6X9 (TAPER)	
710	3-977-443-01	WASHER, STOPPER		723	3-979-508-01	SCREW +HEXA TP SW 3X8	
711	A-6759-863-B	PRESS BLOCK ASSY, PINCH		724	3-059-958-01	SPRING, TG 8	
712	3-958-455-01	SPRING (PINCH), TENSION		725	3-051-300-03	LOCK ACE SCREW	
713	3-977-447-01	GEAR, ELEVATOR					

### 8-1-4. MECHANISM CHASSIS ASSEMBLY (2)

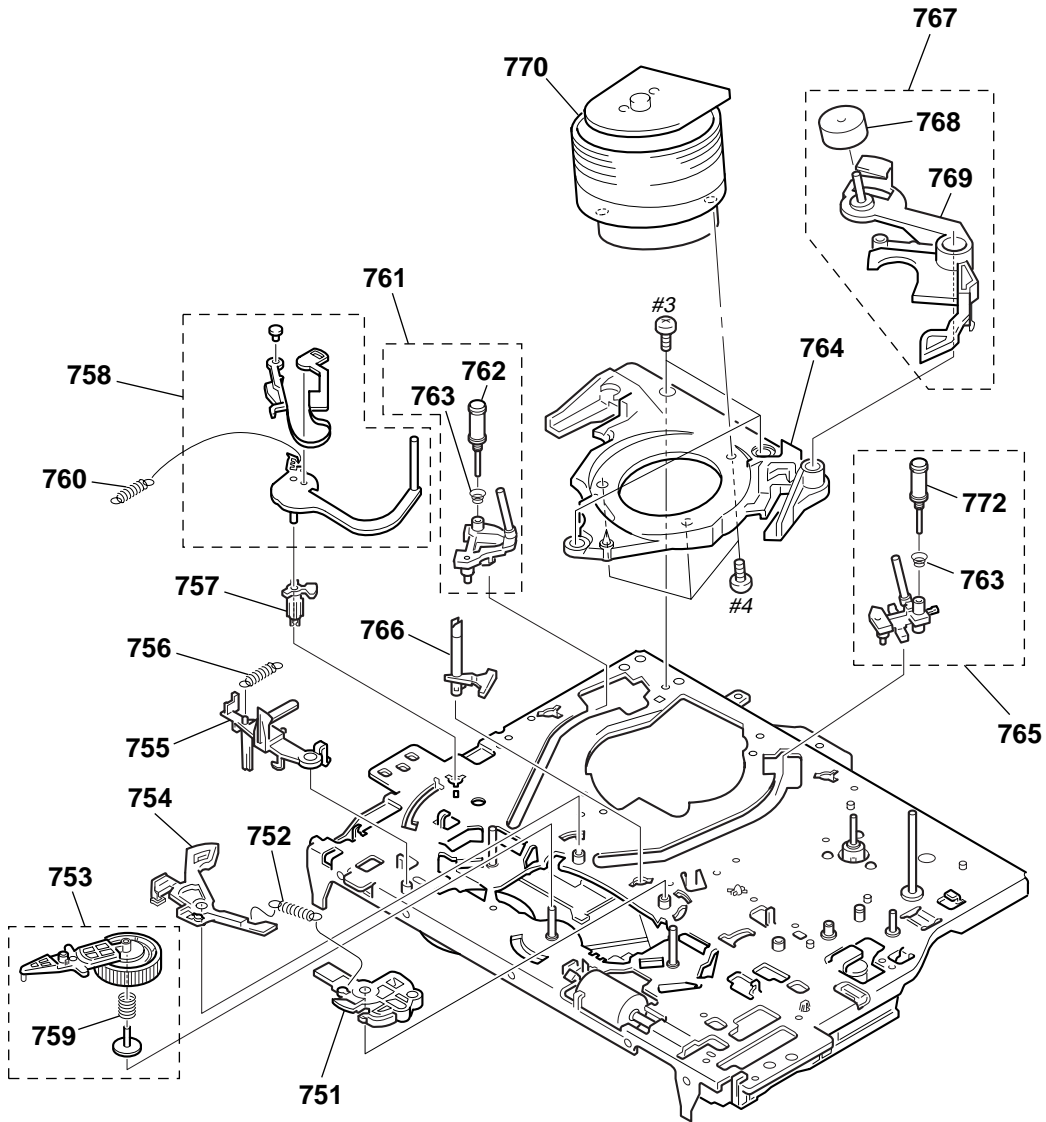

Ref. No.	Part No.	Description	Remark	Ref. No.	Part No.	Description	Remark
751	X-3947-581-4	BRAKE ASSY,MAIN(T)		762	X-3948-050-1	ROLLER ASSY, GUIDE	
752	3-977-462-01	SPRING, EXTENTION. (MAIN BRAKE)		763	3-965-178-01	SPRING	
753	X-3947-573-1	ARM ASSY, PENDULUM		764	3-062-687-01	BASE, DRUM, K (UPPER MOTOR)	
754	X-3947-580-5	BRAKE ASSY, MAIN(S)		765	A-6750-328-E	SHUTTLE (T) BLOCK ASSY	
755	3-063-772-01	LEVER, REC PROOF (SL)		766	3-977-501-01	PLATE, LUMINOUS	
756	3-976-767-01	SPRING, TENS. (REC. PROOF)		767	A-6746-074-G	ROLLER BLOCK ASSY, HC	
757	3-977-487-01	BOSS, TG1 FULCRUM		768	X-3947-255-1	ROLLER ASSY, HC	
758	X-3950-966-1	TG1 ASSY (SL)		769	3-975-724-07	ARM, HC	
759	3-063-958-01	SPRING, COMP (SL PEND)		770	1-772-361-11	DRUM ASSY, DZH-92D-R (SE310)	
760	3-977-488-01	SPRING (POWER TENSION)		770	1-772-362-11	DRUM ASSY, DZH-93D-R (SE410/SE510)	
761	A-6775-463-A	SHUTTLE (S) BLOCK ASSY, ST		772	X-3949-910-1	G. ROLLER ASSY (2PCS)	

### 8-1-5. MECHANISM CHASSIS ASSEMBLY (3)

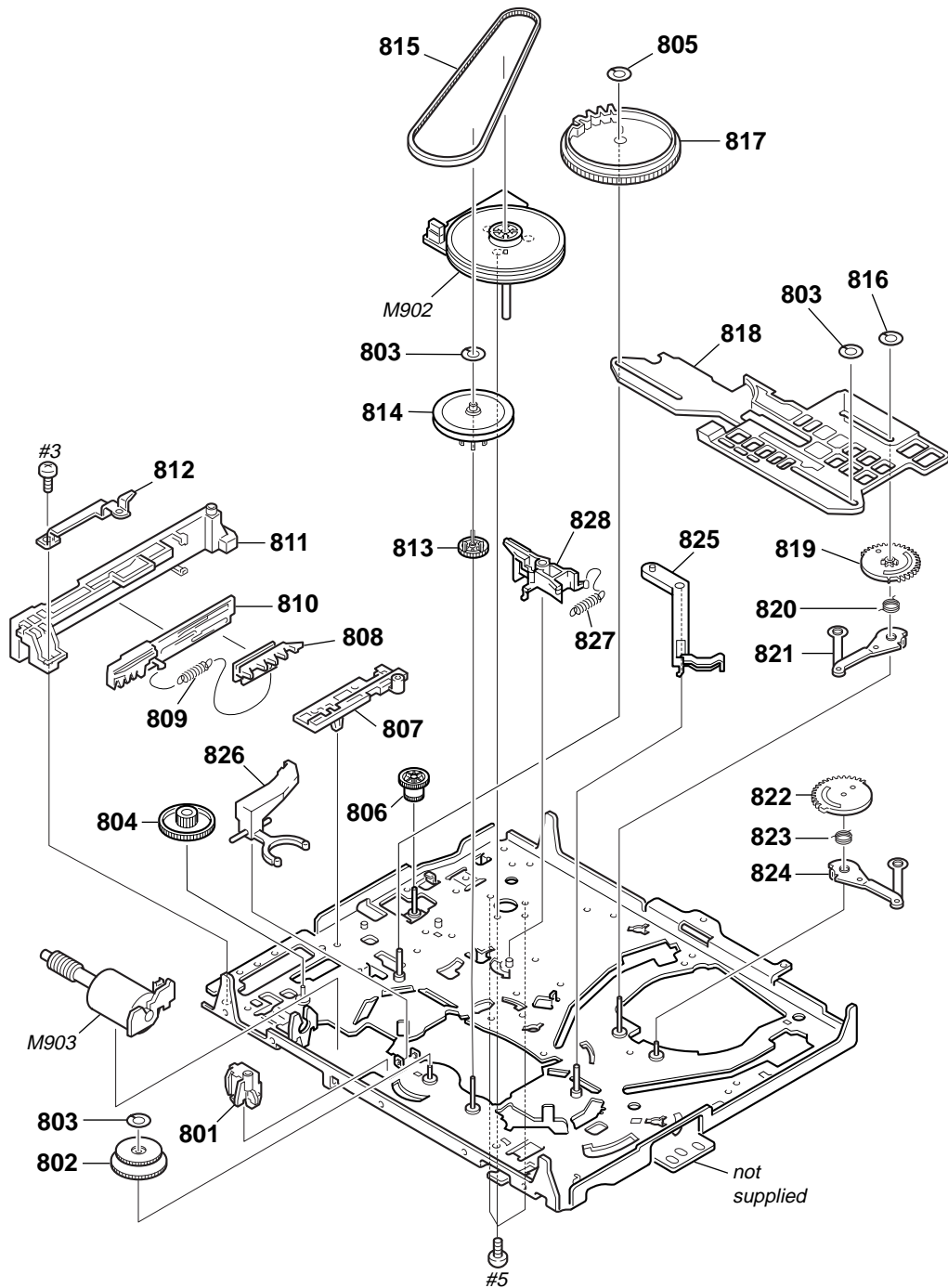

Ref. No.	Part No.	Description	Remark	Ref. No.	Part No.	Description	Remark
801	3-977-437-01	RETAINER, CAM MOTOR		816	3-056-824-01	WASHER, STOPPER	
802	X-3947-584-1	ASSY, REEL DIRECT		817	3-063-755-01	GEAR, CAM H/R	
803	3-977-443-01	WASHER, STOPPER		818	3-063-769-01	SLIDER (S)	
804	3-063-760-01	WORM-WHEEL H/R		819	3-063-757-01	GEAR, LOADING (T) H/R	
805	3-056-952-11	WASHER, STOPPER		820	3-977-456-03	SPRING, TORSION (LOAD T)	
806	3-977-444-01	GEAR, PINCH TRANSMISSION		821	X-3948-132-2	LEVER ASSY, LOADING (T)	
807	3-977-515-01	GUIDE, FL SLIDER		822	3-977-451-01	GEAR, LOADING (S)	
808	3-977-517-01	PLATE, SLIDE, FL		823	3-977-452-01	SPRING, TORSION (LOAD S)	
809	3-977-519-01	SPRING, TENS. (LIMIT, FL)		824	X-3948-131-1	LEVER ASSY, LOADING (S)	
810	3-977-518-02	PLATE, LIMITER, FL		825	3-977-489-01	ARM, TG1 DRIVING	
811	3-977-516-01	HOLDER, FL SLIDER		826	3-977-506-01	ARM, LIMITER SELECTION	
812	3-977-877-01	PLATE, RETAINER		827	3-977-467-02	SPRING, CAP BRAKE	
813	3-977-504-01	GEAR, CLUTCH		828	X-3950-965-1	BRAKE ASSY, CAPSTAN (SL)	
814	X-3947-585-1	GEAR ASSY, PULLEY		M902	1-698-971-11	MOTOR, DC (CAPSTAN)	
815	3-977-510-01	BELT, RUBBER		M903	X-3947-577-1	MOTOR ASSY, CAM	

**8-2. ELECTRICAL PARTS LIST**

**NOTE:**

- Due to standardization, replacements in the parts list may be different from the parts specified in the diagrams or the components used on the set.
- -XX and -X mean standardized parts, so they may have some difference from the original one.
- **RESISTORS**  
All resistors are in ohms.  
METAL: Metal-film resistor.  
METAL OXIDE: Metal oxide-film resistor.  
F: nonflammable

- Items marked “\*” are not stocked since they are seldom required for routine service. Some delay should be anticipated when ordering these items.
- **SEMICONDUCTORS**  
In each case, u:  $\mu$ , for example:  
uA. . :  $\mu$ A. .    uPA. . :  $\mu$ PA. .  
uPB. . :  $\mu$ PB. .    uPC. . :  $\mu$ PC. .  
uPD. . :  $\mu$ PD. .
- **CAPACITORS**  
uF:  $\mu$ F
- **COILS**  
uH:  $\mu$ H
- Not all of the parts for POWER BLOCK (ETXNY272E2D) are listed.

The components identified by mark  $\Delta$  or dotted line with mark  $\Delta$  are critical for safety. Replace only with part number specified.

When indicating parts by reference number, please include the board.

Ref. No.	Part No.	Description	Remark	Ref. No.	Part No.	Description	Remark
*	A-6713-786-A	MA-401 BOARD, COMPLETE (SE510D)		C166	1-163-021-91	CERAMIC CHIP 0.01uF 10% 50V	
*	A-6713-787-A	MA-401 BOARD, COMPLETE (SE310D)		C167	1-163-809-11	CERAMIC CHIP 0.047uF 10% 25V	
*	A-6713-789-A	MA-401 BOARD, COMPLETE (SE510B)		C168	1-163-235-11	CERAMIC CHIP 22PF 5% 50V	
*	A-6713-790-A	MA-401 BOARD, COMPLETE (SE510K)		C169	1-163-235-11	CERAMIC CHIP 22PF 5% 50V	
*	A-6713-791-A	MA-401 BOARD, COMPLETE (SE410K)		C170	1-164-004-11	CERAMIC CHIP 0.1uF 10% 25V	
*	A-6713-792-A	MA-401 BOARD, COMPLETE (SE310I) ***** (Ref.No. 1,000 Series)		C171	1-163-231-11	CERAMIC CHIP 15PF 5% 50V	
	3-064-376-01	HOLDER, FL		C172	1-163-231-11	CERAMIC CHIP 15PF 5% 50V	
	3-960-273-11	SPACER, TOP END		C173	1-163-007-11	CERAMIC CHIP 680PF 10% 50V	
		< CAPACITOR >		C200	1-163-021-91	CERAMIC CHIP 0.01uF 10% 50V	
C100	1-163-009-11	CERAMIC CHIP 0.001uF 10% 50V		C201	1-126-960-11	ELECT 1uF 20% 50V	
C101	1-163-009-11	CERAMIC CHIP 0.001uF 10% 50V		C202	1-163-021-91	CERAMIC CHIP 0.01uF 10% 50V	
C102	1-163-009-11	CERAMIC CHIP 0.001uF 10% 50V		C203	1-163-809-11	CERAMIC CHIP 0.047uF 10% 25V	
C103	1-128-057-11	ELECT 330uF 20% 6.3V		C204	1-163-021-91	CERAMIC CHIP 0.01uF 10% 50V	
C105	1-163-009-11	CERAMIC CHIP 0.001uF 10% 50V		C205	1-163-239-11	CERAMIC CHIP 33PF 5% 50V	(SE410K/SE510)
C107	1-124-589-11	ELECT 47uF 20% 16V		C205	1-163-241-11	CERAMIC CHIP 39PF 5% 50V	(SE310)
C108	1-127-573-11	CERAMIC CHIP 1uF 10% 16V		C206	1-163-809-11	CERAMIC CHIP 0.047uF 10% 25V	
C113	1-163-021-91	CERAMIC CHIP 0.01uF 10% 50V		C207	1-163-237-11	CERAMIC CHIP 27PF 5% 50V	
C114	1-163-021-91	CERAMIC CHIP 0.01uF 10% 50V		C208	1-126-960-11	ELECT 1uF 20% 50V	
C115	1-163-038-11	CERAMIC CHIP 0.1uF 25V		C209	1-163-257-11	CERAMIC CHIP 180PF 5% 50V	
C120	1-163-021-91	CERAMIC CHIP 0.01uF 10% 50V		C210	1-163-237-11	CERAMIC CHIP 27PF 5% 50V	
C121	1-163-021-91	CERAMIC CHIP 0.01uF 10% 50V		C211	1-109-982-11	CERAMIC CHIP 1uF 10% 10V	
C122	1-104-664-11	ELECT 47uF 20% 16V		C212	1-163-809-11	CERAMIC CHIP 0.047uF 10% 25V	
C123	1-163-021-91	CERAMIC CHIP 0.01uF 10% 50V		C213	1-109-982-11	CERAMIC CHIP 1uF 10% 10V	
C131	1-124-589-11	ELECT 47uF 20% 16V		C214	1-164-004-11	CERAMIC CHIP 0.1uF 10% 25V	
C133	1-163-021-91	CERAMIC CHIP 0.01uF 10% 50V		C215	1-163-021-91	CERAMIC CHIP 0.01uF 10% 50V	
C134	1-163-021-91	CERAMIC CHIP 0.01uF 10% 50V		C216	1-163-037-11	CERAMIC CHIP 0.022uF 10% 25V	
C140	1-126-933-11	ELECT 100uF 20% 16V		C217	1-163-021-91	CERAMIC CHIP 0.01uF 10% 50V	
C141	1-163-021-91	CERAMIC CHIP 0.01uF 10% 50V		C218	1-163-021-91	CERAMIC CHIP 0.01uF 10% 50V	
C142	1-163-037-11	CERAMIC CHIP 0.022uF 10% 25V		C219	1-163-038-11	CERAMIC CHIP 0.1uF 25V	
C143	1-126-965-11	ELECT 22uF 20% 50V		C220	1-104-664-11	ELECT 47uF 20% 16V	
C144	1-126-965-11	ELECT 22uF 20% 50V		C221	1-109-982-11	CERAMIC CHIP 1uF 10% 10V	(SE310)
C145	1-126-933-11	ELECT 100uF 20% 16V		C221	1-164-004-11	CERAMIC CHIP 0.1uF 10% 25V	(SE410K/SE510)
C146	1-164-161-11	CERAMIC CHIP 0.0022uF 10% 100V		C222	1-109-982-11	CERAMIC CHIP 1uF 10% 10V	
C160	1-163-021-91	CERAMIC CHIP 0.01uF 10% 50V		C223	1-163-038-11	CERAMIC CHIP 0.1uF 25V	
C161	1-163-021-91	CERAMIC CHIP 0.01uF 10% 50V		C224	1-163-021-91	CERAMIC CHIP 0.01uF 10% 50V	
C162	1-104-905-11	CAPACITOR 0.22F 5.5V		C225	1-124-589-11	ELECT 47uF 20% 16V	
C163	1-163-021-91	CERAMIC CHIP 0.01uF 10% 50V		C226	1-163-021-91	CERAMIC CHIP 0.01uF 10% 50V	
C164	1-126-933-11	ELECT 100uF 20% 16V		C227	1-124-589-11	ELECT 47uF 20% 16V	
C165	1-163-021-91	CERAMIC CHIP 0.01uF 10% 50V		C228	1-163-131-00	CERAMIC CHIP 390PF 5% 50V	
				C229	1-164-004-11	CERAMIC CHIP 0.1uF 10% 25V	



Ref. No.	Part No.	Description	Remark	Ref. No.	Part No.	Description	Remark
C230	1-163-038-11	CERAMIC CHIP	0.1uF	25V	C383	1-104-664-11	ELECT 47uF 20% 16V
C231	1-109-982-11	CERAMIC CHIP	1uF	10% 10V	C384	1-163-251-11	CERAMIC CHIP 100PF 5% 50V
C232	1-109-982-11	CERAMIC CHIP	1uF	10% 10V	C420	1-124-589-11	ELECT 47uF 20% 16V
C233	1-164-004-11	CERAMIC CHIP	0.1uF	10% 25V	C421	1-163-235-11	CERAMIC CHIP 22PF 5% 50V
C234	1-163-021-91	CERAMIC CHIP	0.01uF	10% 50V	C422	1-164-004-11	CERAMIC CHIP 0.1uF 10% 25V
C235	1-109-982-11	CERAMIC CHIP	1uF	10% 10V	C423	1-163-021-91	CERAMIC CHIP 0.01uF 10% 50V
C236	1-163-243-11	CERAMIC CHIP	47PF	5% 50V	C424	1-126-157-11	ELECT 10uF 20% 16V
C237	1-164-004-11	CERAMIC CHIP	0.1uF	10% 25V	C427	1-104-664-11	ELECT 47uF 20% 16V
C238	1-124-261-00	ELECT	10uF	20% 50V	C500	1-163-017-00	CERAMIC CHIP 0.0047uF 5% 50V
C240	1-163-243-11	CERAMIC CHIP	47PF	5% 50V	C502	1-163-017-00	CERAMIC CHIP 0.0047uF 5% 50V
C242	1-164-004-11	CERAMIC CHIP	0.1uF	10% 25V	C510	1-163-021-91	CERAMIC CHIP 0.01uF 10% 50V
C243	1-163-809-11	CERAMIC CHIP	0.047uF	10% 25V	C511	1-104-664-11	ELECT 47uF 20% 16V
C244	1-163-021-91	CERAMIC CHIP	0.01uF	10% 50V	C512	1-104-664-11	ELECT 47uF 20% 16V
C245	1-164-004-11	CERAMIC CHIP	0.1uF	10% 25V	C513	1-126-935-11	ELECT 470uF 20% 6.3V
C246	1-163-021-91	CERAMIC CHIP	0.01uF	10% 50V	C570	1-163-017-00	CERAMIC CHIP 0.0047uF 5% 50V
C247	1-163-021-91	CERAMIC CHIP	0.01uF	10% 50V	C571	1-163-017-00	CERAMIC CHIP 0.0047uF 5% 50V
C248	1-124-589-11	ELECT	47uF	20% 16V	C572	1-163-017-00	CERAMIC CHIP 0.0047uF 5% 50V
C249	1-126-157-11	ELECT	10uF	20% 16V	C580	1-124-261-00	ELECT 10uF 20% 50V
C250	1-124-589-11	ELECT	47uF	20% 16V	C581	1-126-964-11	ELECT 10uF 20% 50V
C251	1-126-965-11	ELECT	22uF	20% 50V	C582	1-126-964-11	ELECT 10uF 20% 50V
C252	1-109-982-11	CERAMIC CHIP	1uF	10% 10V	C583	1-126-964-11	ELECT 10uF 20% 50V
C253	1-163-133-00	CERAMIC CHIP	470PF	5% 50V	C584	1-164-004-11	CERAMIC CHIP 0.1uF 10% 25V
C255	1-163-021-91	CERAMIC CHIP	0.01uF	10% 50V	C585	1-126-964-11	ELECT 10uF 20% 50V
C271	1-163-021-91	CERAMIC CHIP	0.01uF	10% 50V	C586	1-126-964-11	ELECT 10uF 20% 50V
C272	1-164-004-11	CERAMIC CHIP	0.1uF	10% 25V	C587	1-126-964-11	ELECT 10uF 20% 50V
C275	1-163-021-91	CERAMIC CHIP	0.01uF	10% 50V	C588	1-126-964-11	ELECT 10uF 20% 50V
C276	1-164-004-11	CERAMIC CHIP	0.1uF	10% 25V	C601	1-163-021-91	CERAMIC CHIP 0.01uF 10% 50V
C278	1-163-037-11	CERAMIC CHIP	0.022uF	10% 25V	C603	1-128-131-11	ELECT 22uF 20% 50V
C279	1-164-004-11	CERAMIC CHIP	0.1uF	10% 25V	C604	1-104-664-11	ELECT 47uF 20% 16V
C280	1-124-584-00	ELECT	100uF	20% 10V	C605	1-126-964-11	ELECT 10uF 20% 50V
C281	1-163-021-91	CERAMIC CHIP	0.01uF	10% 50V	C607	1-163-021-91	CERAMIC CHIP 0.01uF 10% 50V
C282	1-163-021-91	CERAMIC CHIP	0.01uF	10% 50V	C611	1-104-664-11	ELECT 47uF 20% 16V
C283	1-163-021-91	CERAMIC CHIP	0.01uF	10% 50V	C612	1-163-021-91	CERAMIC CHIP 0.01uF 10% 50V
C284	1-164-489-11	CERAMIC CHIP	0.22uF	10% 16V	C613	1-126-933-11	ELECT 100uF 20% 16V
C285	1-163-021-91	CERAMIC CHIP	0.01uF	10% 50V	C615	1-126-965-11	ELECT 22uF 20% 50V
C288	1-163-251-11	CERAMIC CHIP	100PF	5% 50V	C620	1-164-004-11	CERAMIC CHIP 0.1uF 10% 25V
C289	1-163-233-11	CERAMIC CHIP	18PF	5% 50V	C660	1-163-233-11	CERAMIC CHIP 18PF 5% 50V
C350	1-164-489-11	CERAMIC CHIP	0.22uF	10% 16V	C661	1-163-233-11	CERAMIC CHIP 18PF 5% 50V
C351	1-104-664-11	ELECT	47uF	20% 16V	C662	1-163-017-00	CERAMIC CHIP 0.0047uF 5% 50V
C352	1-163-038-11	CERAMIC CHIP	0.1uF	25V	C663	1-163-021-91	CERAMIC CHIP 0.01uF 10% 50V
C354	1-126-964-11	ELECT	10uF	20% 50V	C664	1-164-004-11	CERAMIC CHIP 0.1uF 10% 25V
C355	1-164-489-11	CERAMIC CHIP	0.22uF	10% 16V	C665	1-163-245-11	CERAMIC CHIP 56PF 5% 50V
C356	1-126-966-11	ELECT	33uF	20% 16V	C666	1-163-135-00	CERAMIC CHIP 560PF 5% 50V
C357	1-126-963-11	ELECT	4.7uF	20% 50V	C667	1-163-021-91	CERAMIC CHIP 0.01uF 10% 50V
C358	1-109-982-11	CERAMIC CHIP	1uF	10% 10V	C668	1-124-584-00	ELECT 100uF 20% 10V
C359	1-163-010-11	CERAMIC CHIP	0.0012uF	10% 50V	C669	1-163-016-00	CERAMIC CHIP 0.0039uF 10% 50V
C360	1-163-011-11	CERAMIC CHIP	0.0015uF	10% 50V	C670	1-109-982-11	CERAMIC CHIP 1uF 10% 10V
C361	1-163-021-91	CERAMIC CHIP	0.01uF	10% 50V	C671	1-163-235-11	CERAMIC CHIP 22PF 5% 50V
C362	1-104-664-11	ELECT	47uF	20% 16V	C672	1-163-021-91	CERAMIC CHIP 0.01uF 10% 50V
C363	1-126-963-11	ELECT	4.7uF	20% 50V	C701	1-126-964-11	ELECT 10uF 20% 50V
C364	1-126-964-11	ELECT	10uF	20% 50V	C704	1-126-964-11	ELECT 10uF 20% 50V
C365	1-163-021-91	CERAMIC CHIP	0.01uF	10% 50V	C705	1-163-809-11	CERAMIC CHIP 0.047uF 10% 25V
C366	1-126-960-11	ELECT	1uF	20% 50V	C708	1-104-664-11	ELECT 47uF 20% 16V
C367	1-163-021-91	CERAMIC CHIP	0.01uF	10% 50V	C709	1-163-021-91	CERAMIC CHIP 0.01uF 10% 50V
C380	1-137-374-11	MYLAR	0.047uF	5% 50V	C710	1-126-965-11	ELECT 22uF 20% 50V
C381	1-163-021-91	CERAMIC CHIP	0.01uF	10% 50V	C721	1-128-131-11	ELECT 22uF 20% 50V
C382	1-163-021-91	CERAMIC CHIP	0.01uF	10% 50V	C752	1-126-933-11	ELECT 100uF 20% 16V
					C753	1-164-004-11	CERAMIC CHIP 0.1uF 10% 25V

**MA-401**

Ref. No.	Part No.	Description	Remark	Ref. No.	Part No.	Description	Remark
C754	1-126-935-11	ELECT	470uF 20% 6.3V			< CONNECTOR >	
C801	1-163-021-91	CERAMIC CHIP	0.01uF 10% 50V (SE310/SE510)	CN101	1-695-328-11	HOUSING, CONNECTOR 5P	
C850	1-163-038-11	CERAMIC CHIP	0.1uF 25V (SE310/SE510)	CN102	1-779-723-11	CONNECTOR, BOARD TO BOARD 9P	
C851	1-124-261-00	ELECT	10uF 20% 50V (SE310/SE510)	* CN104	1-766-716-11	CONNECTOR, BOARD TO BOARD 3P	
C852	1-164-161-11	CERAMIC CHIP	0.0022uF 10% 100V (SE310/SE510)	* CN161	1-506-469-11	PIN, CONNECTOR 4P	
C853	1-163-989-11	CERAMIC CHIP	0.033uF 10% 25V (SE310/SE510)	CN261	1-793-919-11	CONNECTOR, FFC/FPC 6P	
C855	1-164-489-11	CERAMIC CHIP	0.22uF 10% 16V (SE310/SE510)	* CN262	1-560-893-00	PIN, CONNECTOR 5P	
C856	1-163-038-11	CERAMIC CHIP	0.1uF 25V (SE310/SE510)	CN350	1-784-486-11	CONNECTOR, FFC/FPC 7P	
C970	1-163-259-91	CERAMIC CHIP	220PF 5% 50V (SE510B)	CN351	1-506-468-11	PIN, CONNECTOR 3P	
C971	1-124-257-00	ELECT	2.2uF 20% 50V (SE510B)	CN460	1-506-469-11	PIN, CONNECTOR 4P	
C972	1-163-017-00	CERAMIC CHIP	0.0047uF 5% 50V (SE510B)	CN500	1-793-918-11	CONNECTOR, SQUARE TYPE 21P	(LINE-1 (TV))
C973	1-163-021-91	CERAMIC CHIP	0.01uF 10% 50V (SE510B)	CN570	1-793-918-11	CONNECTOR, SQUARE TYPE 21P	(DECODER/LINE-2)
C974	1-109-982-11	CERAMIC CHIP	1uF 10% 10V (SE510B)	CN600	1-569-340-11	CONNECTOR, BOARD TO BOARD 11P	
C975	1-163-037-11	CERAMIC CHIP	0.022uF 10% 25V (SE510B)			< DIODE >	
C976	1-163-259-91	CERAMIC CHIP	220PF 5% 50V (SE510B)	D100	8-719-048-26	DIODE GL528V1 (T/S.LED)	
C977	1-163-021-91	CERAMIC CHIP	0.01uF 10% 50V (SE510B)	D110	8-719-200-82	DIODE MPG06D-6052PKG3	
C978	1-163-017-00	CERAMIC CHIP	0.0047uF 5% 50V (SE510B)	D420	8-719-059-98	DIODE SLR-342VCT31 (SYNCHRO REC)	(SE310/SE510)
C979	1-163-255-11	CERAMIC CHIP	150PF 5% 50V (SE510B)	D421	8-719-988-61	DIODE 1SS355TE-17 (SE310/SE510)	
C980	1-164-004-11	CERAMIC CHIP	0.1uF 10% 25V (SE510B)	D424	8-719-067-40	DIODE STZ6.8N-T146	
C981	1-163-021-91	CERAMIC CHIP	0.01uF 10% 50V (SE510B)	D500	8-719-067-40	DIODE STZ6.8N-T146	
C982	1-163-007-11	CERAMIC CHIP	680PF 10% 50V (SE510B)	D504	8-719-067-40	DIODE STZ6.8N-T146	
C983	1-163-009-11	CERAMIC CHIP	0.001uF 10% 50V (SE510B)	D508	8-719-070-59	DIODE PDZ6.8B-115	
C984	1-163-021-91	CERAMIC CHIP	0.01uF 10% 50V (SE510B)	D511	8-719-070-59	DIODE PDZ6.8B-115	
C985	1-163-251-11	CERAMIC CHIP	100PF 5% 50V (SE510B)	D512	8-719-977-40	DIODE UDZ-TE-17-13B	
C986	1-126-157-11	ELECT	10uF 20% 16V (SE510B)	D513	8-719-067-40	DIODE STZ6.8N-T146	
C987	1-107-823-11	CERAMIC CHIP	0.47uF 10% 16V (SE510B)	D514	8-719-977-40	DIODE UDZ-TE-17-13B	
C988	1-163-251-11	CERAMIC CHIP	100PF 5% 50V (SE510B)	D515	8-719-067-40	DIODE STZ6.8N-T146	
C991	1-164-004-11	CERAMIC CHIP	0.1uF 10% 25V (SE510B)	D540	8-719-067-40	DIODE STZ6.8N-T146	
C992	1-163-021-91	CERAMIC CHIP	0.01uF 10% 50V (SE510B)	D542	8-719-067-40	DIODE STZ6.8N-T146	
C993	1-163-021-91	CERAMIC CHIP	0.01uF 10% 50V (SE510B)	D544	8-719-070-59	DIODE PDZ6.8B-115	(SE310D/SE410K/SE510)
C994	1-163-021-91	CERAMIC CHIP	0.01uF 10% 50V (SE510B)	D570	8-719-070-59	DIODE PDZ6.8B-115	
C995	1-126-157-11	ELECT	10uF 20% 16V (SE510B)	D571	8-719-067-40	DIODE STZ6.8N-T146	
C996	1-163-227-11	CERAMIC CHIP	10PF 0.5PF 50V (SE510B)	D575	8-719-067-40	DIODE STZ6.8N-T146	(SE310D/SE410K/SE510)
				D576	8-719-977-40	DIODE UDZ-TE-17-13B	
				D590	8-719-988-61	DIODE 1SS355TE-17	
				D591	8-719-988-61	DIODE 1SS355TE-17	
				D600	8-719-988-61	DIODE 1SS355TE-17	
				D601	8-719-988-61	DIODE 1SS355TE-17	
				D602	8-719-070-56	DIODE PDZ5.1B-115	
				D603	8-719-075-84	DIODE S1G-G2P	
				D606	8-719-075-84	DIODE S1G-G2P	
				D607	8-719-075-84	DIODE S1G-G2P	
				D702	8-719-982-26	DIODE MTZJ-T-77-33	
				D750	8-719-075-84	DIODE S1G-G2P	
				D800	8-719-988-61	DIODE 1SS355TE-17 (SE310/SE510)	
						< GROUND TERMINAL >	
				ET600	1-537-770-21	TERMINAL BOARD, GROUND	
				ET601	1-537-770-21	TERMINAL BOARD, GROUND	
						< FILTER >	
				FL500	1-236-163-11	ENCAPSULATED COMPONENT	
				FL502	1-236-163-11	ENCAPSULATED COMPONENT	

Ref. No.	Part No.	Description	Remark	Ref. No.	Part No.	Description	Remark
FL570	1-236-163-11	ENCAPSULATED COMPONENT		JR038	1-216-296-11	SHORT	0
FL572	1-236-163-11	ENCAPSULATED COMPONENT (SE310D/SE410K/SE510)		JR039	1-216-296-11	SHORT	0
		< IC >		JR040	1-216-296-11	SHORT	0
				JR041	1-216-296-11	SHORT	0
IC130	8-759-645-07	IC LB1943N		JR042	1-216-296-11	SHORT	0
IC160	8-759-248-87	IC MM1256XF-BE		JR043	1-216-296-11	SHORT	0
IC161	8-759-575-72	IC M24C08-WMN6T (A)		JR044	1-216-296-11	SHORT	0
IC162	8-759-837-13	IC M37760MFH703GP (SE410K)		JR201	1-216-295-11	SHORT	0
IC162	8-759-837-14	IC M37760MFH704GP (SE310/SE510)		JR202	1-216-295-11	SHORT	0
IC200	8-759-638-71	IC LA71562M-MPB		JR203	1-216-295-11	SHORT	0
IC260	8-759-549-79	IC LA70001 (SE310)		JR204	1-216-295-11	SHORT	0
IC260	8-759-564-36	IC LA70011 (SE410K/SE510)		JR205	1-216-295-11	SHORT	0
IC350	8-759-499-30	IC BA7755AF-E2		JR206	1-216-295-11	SHORT	0
IC420	8-759-547-59	IC M35500BGP		JR207	1-216-295-11	SHORT	0
IC460	8-759-830-96	IC SFH5110-40		JR208	1-216-295-11	SHORT	0
IC580	8-759-009-07	IC MC14053BFEL		JR209	1-216-295-11	SHORT	0
△IC601	8-759-438-18	IC PQ12RD08		JR210	1-216-295-11	SHORT	0
IC850	8-759-484-61	IC SDA5650X-GEG (SE310/SE510)		JR211	1-216-295-11	SHORT	0
IC970	8-759-438-17	IC LA7337 (SE510B)		JR212	1-216-295-11	SHORT	0
		< JUMPER RESISTOR >		JR213	1-216-295-11	SHORT	0
JR001	1-216-296-11	SHORT	0	JR214	1-216-295-11	SHORT	0 (SE510B)
JR002	1-216-296-11	SHORT	0 (SE510B)	JR215	1-216-295-11	SHORT	0 (SE510B)
JR003	1-216-296-11	SHORT	0	JR216	1-216-295-11	SHORT	0
JR004	1-216-296-11	SHORT	0	JR217	1-216-295-11	SHORT	0
JR005	1-216-296-11	SHORT	0	JR218	1-216-295-11	SHORT	0
JR006	1-216-296-11	SHORT	0	JR219	1-216-295-11	SHORT	0
JR007	1-216-296-11	SHORT	0 (SE510B)	JR220	1-216-295-11	SHORT	0
JR008	1-216-296-11	SHORT	0	JR221	1-216-295-11	SHORT	0
JR009	1-216-296-11	SHORT	0	JR222	1-216-295-11	SHORT	0
JR011	1-216-296-11	SHORT	0	JR223	1-216-295-11	SHORT	0
JR012	1-216-296-11	SHORT	0	JR226	1-216-295-11	SHORT	0
JR013	1-216-296-11	SHORT	0	JR227	1-216-295-11	SHORT	0
JR014	1-216-296-11	SHORT	0 (SE510B)	JR228	1-216-295-11	SHORT	0
JR015	1-216-296-11	SHORT	0 (SE510B)	JR229	1-216-295-11	SHORT	0
JR016	1-216-296-11	SHORT	0	JR230	1-216-295-11	SHORT	0
JR017	1-216-296-11	SHORT	0 (SE510B)	JR231	1-216-296-11	SHORT	0
JR018	1-216-296-11	SHORT	0	JR232	1-216-296-11	SHORT	0
JR019	1-216-296-11	SHORT	0			< COIL >	
JR020	1-216-296-11	SHORT	0	L140	1-414-936-21	INDUCTOR	22uH
JR021	1-216-296-11	SHORT	0	L160	1-414-936-21	INDUCTOR	22uH
JR022	1-216-296-11	SHORT	0	L161	1-414-936-21	INDUCTOR	22uH
JR023	1-216-296-11	SHORT	0 (SE510B)	L200	1-414-946-21	INDUCTOR	39uH
JR024	1-216-296-11	SHORT	0	L201	1-414-940-21	INDUCTOR	100uH
JR025	1-216-296-11	SHORT	0 (SE310/SE510)	L202	1-414-934-21	INDUCTOR	10uH
JR026	1-216-296-11	SHORT	0	L203	1-414-934-21	INDUCTOR	10uH
JR027	1-216-296-11	SHORT	0	L204	1-414-934-21	INDUCTOR	10uH
JR028	1-216-296-11	SHORT	0	L205	1-414-934-21	INDUCTOR	10uH
JR029	1-216-296-11	SHORT	0	L206	1-414-938-21	INDUCTOR	47uH (SE510B)
JR030	1-216-296-11	SHORT	0	L270	1-414-940-21	INDUCTOR	100uH
JR031	1-216-296-11	SHORT	0	L271	1-414-930-21	INDUCTOR	2.2uH
JR032	1-216-296-11	SHORT	0	L350	1-414-940-21	INDUCTOR	100uH
JR033	1-216-296-11	SHORT	0	L351	1-414-479-11	INDUCTOR	47nH
JR034	1-216-296-11	SHORT	0	L352	1-414-479-11	INDUCTOR	47nH
JR035	1-216-296-11	SHORT	0 (SE510B)	L353	1-414-479-11	INDUCTOR	47nH
JR036	1-216-296-11	SHORT	0	L354	1-414-479-11	INDUCTOR	47nH
JR037	1-216-295-11	SHORT	0	L355	1-414-479-11	INDUCTOR	47nH
				L356	1-414-479-11	INDUCTOR	47nH

The components identified by mark △ or dotted line with mark △ are critical for safety.  
Replace only with part number specified.

# MA-401

Ref. No.	Part No.	Description	Remark	Ref. No.	Part No.	Description	Remark
L357	1-414-479-11	INDUCTOR	47nH	Q582	8-729-043-29	TRANSISTOR	PDTC144EK-115
L358	1-414-479-11	INDUCTOR	47nH	Q583	8-729-422-33	TRANSISTOR	2PD601AR-115
L359	1-414-479-11	INDUCTOR	47nH	Q591	8-729-422-33	TRANSISTOR	2PD601AR-115
L360	1-414-479-11	INDUCTOR	47nH	Q600	8-729-018-99	TRANSISTOR	2SD2394-F
L361	1-414-479-11	INDUCTOR	47nH	△ Q601	8-729-140-93	TRANSISTOR	2SB733-T-34
L380	1-414-940-21	INDUCTOR	100uH	Q602	8-729-140-96	TRANSISTOR	2SD774-T-4
L460	1-414-938-21	INDUCTOR	47uH	Q603	8-729-422-33	TRANSISTOR	2PD601AR-115
L510	1-414-940-21	INDUCTOR	100uH	Q604	8-729-119-79	TRANSISTOR	2SC2785TP-FEK
L580	1-414-940-21	INDUCTOR	100uH	Q605	8-729-043-32	TRANSISTOR	PDTA114EK-115
L601	1-414-934-21	INDUCTOR	10uH	Q606	8-729-043-29	TRANSISTOR	PDTC144EK-115
L660	1-414-930-21	INDUCTOR	2.2uH	Q607	8-729-804-41	TRANSISTOR	2SB1122-ST-TD
L661	1-414-936-21	INDUCTOR	22uH (SE410K/SE510: B, K)	Q608	8-729-043-29	TRANSISTOR	PDTC144EK-115
L662	1-414-936-21	INDUCTOR	22uH	Q611	8-729-422-33	TRANSISTOR	2PD601AR-115
L663	1-414-936-21	INDUCTOR	22uH	Q612	8-729-804-41	TRANSISTOR	2SB1122-ST-TD
L701	1-414-930-21	INDUCTOR	2.2uH	Q613	8-729-043-29	TRANSISTOR	PDTC144EK-115
L720	1-414-939-21	INDUCTOR	68uH	Q660	8-729-216-22	TRANSISTOR	2PB709AR-115
L721	1-414-936-21	INDUCTOR	22uH	Q661	8-729-216-22	TRANSISTOR	2PB709AR-115
L750	1-414-930-21	INDUCTOR	2.2uH	Q720	8-729-119-76	TRANSISTOR	2SA1309A-QRSTA
L970	1-414-933-21	INDUCTOR	6.8uH (SE510B)	Q721	8-729-422-33	TRANSISTOR	2PD601AR-115
L971	1-414-945-21	INDUCTOR	27uH (SE510B)	Q751	8-729-043-29	TRANSISTOR	PDTC144EK-115
L972	1-414-938-21	INDUCTOR	47uH (SE510B)	Q752	8-729-216-22	TRANSISTOR	2PB709AR-115
L973	1-414-938-21	INDUCTOR	47uH (SE510B)	Q800	8-729-216-22	TRANSISTOR	2PB709AR-115
L975	1-414-934-21	INDUCTOR	10uH (SE510B)	Q801	8-729-422-33	TRANSISTOR	2PD601AR-115 (SE310/SE510)
< FLUORESCENT INDICATOR >				Q802	8-729-422-33	TRANSISTOR	2PD601AR-115 (SE310/SE510)
ND420	1-517-833-11	INDICATOR TUBE, FLUORESCENT		Q803	8-729-422-33	TRANSISTOR	2PD601AR-115 (SE310/SE510)
< PHOTO INTERRUPTER >				Q804	8-729-043-29	TRANSISTOR	PDTC144EK-115 (SE310/SE510)
PH100	8-749-015-86	PHOTO INTERRUPTER GP3S120S		Q850	8-729-216-22	TRANSISTOR	2PB709AR-115 (SE310/SE510)
PH101	8-749-015-86	PHOTO INTERRUPTER GP3S120S		Q970	8-729-216-22	TRANSISTOR	2PB709AR-115 (SE510B)
< IC LINK >				Q972	8-729-043-32	TRANSISTOR	PDTA114EK-115 (SE510B)
△ PS120	1-532-605-00	LINK, IC (0.4A)		Q973	8-729-422-33	TRANSISTOR	2PD601AR-115 (SE510B)
△ PS600	1-532-637-00	LINK, IC (1.0A)		Q974	8-729-422-33	TRANSISTOR	2PD601AR-115 (SE510B)
△ PS602	1-532-727-11	LINK, IC (0.25A)		Q975	8-729-043-32	TRANSISTOR	PDTA114EK-115 (SE510B)
< TRANSISTOR >				Q976	8-729-043-29	TRANSISTOR	PDTC144EK-115 (SE510B)
Q100	8-729-043-84	TRANSISTOR	PT380F3 (S SENS)	< RESISTOR >			
Q101	8-729-043-84	TRANSISTOR	PT380F3 (T SENS)	R100	1-216-077-91	RES-CHIP	15K 5% 1/10W
Q102	8-729-281-53	TRANSISTOR	2SC1815GR-TPE2	R101	1-249-413-11	CARBON	470 5% 1/4W F
Q200	8-729-422-33	TRANSISTOR	2PD601AR-115	R102	1-216-077-91	RES-CHIP	15K 5% 1/10W
Q201	8-729-422-33	TRANSISTOR	2PD601AR-115	R103	1-216-081-00	METAL CHIP	22K 5% 1/10W
Q202	8-729-422-33	TRANSISTOR	2PD601AR-115	R104	1-216-049-11	RES-CHIP	1K 5% 1/10W
Q203	8-729-216-22	TRANSISTOR	2PB709AR-115	R105	1-216-057-00	METAL CHIP	2.2K 5% 1/10W
Q204	8-729-043-29	TRANSISTOR	PDTC144EK-115 (SE510B)	R106	1-249-400-11	CARBON	39 5% 1/4W F
Q350	8-729-281-53	TRANSISTOR	2SC1815GR-TPE2	R107	1-249-400-11	CARBON	39 5% 1/4W F
Q380	8-729-802-91	TRANSISTOR	2SD879-AA	R108	1-216-081-00	METAL CHIP	22K 5% 1/10W
Q501	8-729-043-32	TRANSISTOR	PDTA114EK-115	R114	1-216-089-11	RES-CHIP	47K 5% 1/10W
Q502	8-729-043-29	TRANSISTOR	PDTC144EK-115	R115	1-216-089-11	RES-CHIP	47K 5% 1/10W
Q510	8-729-216-22	TRANSISTOR	2PB709AR-115	R120	1-216-089-11	RES-CHIP	47K 5% 1/10W
Q540	8-729-216-22	TRANSISTOR	2PB709AR-115 (SE310D/SE410K/SE510)	R121	1-216-089-11	RES-CHIP	47K 5% 1/10W
Q541	8-729-216-22	TRANSISTOR	2PB709AR-115 (SE310D/SE410K/SE510)	R123	1-216-065-91	RES-CHIP	4.7K 5% 1/10W
Q580	8-729-043-29	TRANSISTOR	PDTC144EK-115	R124	1-216-041-00	METAL CHIP	470 5% 1/10W
Q581	8-729-043-29	TRANSISTOR	PDTC144EK-115 (SE310D/SE410K/SE510)	R130	1-216-077-91	RES-CHIP	15K 5% 1/10W
				R132	1-216-041-00	METAL CHIP	470 5% 1/10W
				R133	1-216-089-11	RES-CHIP	47K 5% 1/10W

The components identified by mark △ or dotted line with mark △ are critical for safety.  
Replace only with part number specified.

Ref. No.	Part No.	Description			Remark	Ref. No.	Part No.	Description			Remark
R142	1-216-051-00	METAL CHIP	1.2K	5%	1/10W	R216	1-216-109-00	METAL CHIP	330K	5%	1/10W
R143	1-216-065-91	RES-CHIP	4.7K	5%	1/10W						(SE410K/SE510)
R160	1-216-053-00	METAL CHIP	1.5K	5%	1/10W	R216	1-216-117-00	METAL CHIP	680K	5%	1/10W
					(SE510D)						(SE310)
R160	1-216-061-00	METAL CHIP	3.3K	5%	1/10W	R217	1-216-025-11	RES-CHIP	100	5%	1/10W
					(SE310I)						(SE310D/SE410K/SE510)
R160	1-216-067-00	METAL CHIP	5.6K	5%	1/10W	R218	1-216-295-11	SHORT	0		
					(SE510B)	R219	1-216-017-91	RES-CHIP	47	5%	1/10W
R160	1-216-071-00	METAL CHIP	8.2K	5%	1/10W	R220	1-216-049-11	RES-CHIP	1K	5%	1/10W
					(SE410K/SE510K)	R221	1-216-017-91	RES-CHIP	47	5%	1/10W
R160	1-216-295-11	SHORT	0		(SE310D)	R223	1-216-017-91	RES-CHIP	47	5%	1/10W
R161	1-216-053-00	METAL CHIP	1.5K	5%	1/10W	R224	1-216-057-00	METAL CHIP	2.2K	5%	1/10W
					(SE410K/SE510D)	R225	1-216-057-00	METAL CHIP	2.2K	5%	1/10W
R161	1-216-061-00	METAL CHIP	3.3K	5%	1/10W	R226	1-216-055-00	METAL CHIP	1.8K	5%	1/10W
					(SE510: B, K)	R227	1-216-295-11	SHORT	0		
R161	1-216-067-00	METAL CHIP	5.6K	5%	1/10W	R228	1-216-295-11	SHORT	0		(SE510B)
					(SE310D)						
R161	1-216-079-00	METAL CHIP	18K	5%	1/10W	R232	1-216-077-91	RES-CHIP	15K	5%	1/10W
					(SE310I)						(SE310)
R162	1-216-073-00	METAL CHIP	10K	5%	1/10W	R232	1-216-085-00	METAL CHIP	33K	5%	1/10W
											(SE410K/SE510)
R163	1-216-073-00	METAL CHIP	10K	5%	1/10W	R233	1-216-065-91	RES-CHIP	4.7K	5%	1/10W
R164	1-216-073-00	METAL CHIP	10K	5%	1/10W						(SE510B)
R165	1-216-061-00	METAL CHIP	3.3K	5%	1/10W	R235	1-216-089-11	RES-CHIP	47K	5%	1/10W
R166	1-216-061-00	METAL CHIP	3.3K	5%	1/10W	R236	1-216-089-11	RES-CHIP	47K	5%	1/10W
R167	1-216-069-00	METAL CHIP	6.8K	5%	1/10W						
R168	1-216-101-00	METAL CHIP	150K	5%	1/10W	R270	1-216-043-91	RES-CHIP	560	5%	1/10W
R169	1-216-113-00	METAL CHIP	470K	5%	1/10W						(SE410K/SE510)
R170	1-216-061-00	METAL CHIP	3.3K	5%	1/10W	R271	1-216-043-91	RES-CHIP	560	5%	1/10W
R171	1-216-073-00	METAL CHIP	10K	5%	1/10W	R272	1-216-055-00	METAL CHIP	1.8K	5%	1/10W
R176	1-216-037-00	METAL CHIP	330	5%	1/10W						(SE310)
R177	1-216-041-00	METAL CHIP	470	5%	1/10W	R272	1-216-059-00	METAL CHIP	2.7K	5%	1/10W
R178	1-216-041-00	METAL CHIP	470	5%	1/10W						(SE410K/SE510)
R179	1-216-041-00	METAL CHIP	470	5%	1/10W	R273	1-216-295-11	SHORT	0		
R180	1-216-069-00	METAL CHIP	6.8K	5%	1/10W	R274	1-216-065-91	RES-CHIP	4.7K	5%	1/10W
R181	1-216-061-00	METAL CHIP	3.3K	5%	1/10W						(SE410K/SE510)
R182	1-216-041-00	METAL CHIP	470	5%	1/10W	R274	1-216-067-00	METAL CHIP	5.6K	5%	1/10W
R183	1-216-041-00	METAL CHIP	470	5%	1/10W						(SE310)
R184	1-216-295-11	SHORT	0			R276	1-216-071-00	METAL CHIP	8.2K	5%	1/10W
R185	1-216-295-11	SHORT	0								(SE410K/SE510)
R189	1-216-049-11	RES-CHIP	1K	5%	1/10W	R276	1-216-077-91	RES-CHIP	15K	5%	1/10W
											(SE310)
R196	1-216-061-00	METAL CHIP	3.3K	5%	1/10W	R277	1-216-081-00	METAL CHIP	22K	5%	1/10W
R200	1-216-073-00	METAL CHIP	10K	5%	1/10W	R278	1-216-081-00	METAL CHIP	22K	5%	1/10W
R203	1-216-055-00	METAL CHIP	1.8K	5%	1/10W	R279	1-216-081-00	METAL CHIP	22K	5%	1/10W
R204	1-216-037-00	METAL CHIP	330	5%	1/10W	R280	1-216-097-11	RES-CHIP	100K	5%	1/10W
R205	1-216-037-00	METAL CHIP	330	5%	1/10W	R283	1-216-295-11	SHORT	0		
						R284	1-216-295-11	SHORT	0		
R206	1-216-045-00	METAL CHIP	680	5%	1/10W	R286	1-216-025-11	RES-CHIP	100	5%	1/10W
					(SE410K/SE510)	R350	1-216-093-91	RES-CHIP	68K	5%	1/10W
R206	1-216-047-91	RES-CHIP	820	5%	1/10W	R351	1-216-067-00	METAL CHIP	5.6K	5%	1/10W
					(SE310)	R354	1-216-129-00	METAL CHIP	2.2M	5%	1/10W
R207	1-216-047-91	RES-CHIP	820	5%	1/10W	R355	1-216-093-91	RES-CHIP	68K	5%	1/10W
					(SE310)						
R207	1-216-059-00	METAL CHIP	2.7K	5%	1/10W	R356	1-216-067-00	METAL CHIP	5.6K	5%	1/10W
					(SE410K/SE510)	R357	1-216-071-00	METAL CHIP	8.2K	5%	1/10W
R208	1-216-065-91	RES-CHIP	4.7K	5%	1/10W	R358	1-216-055-00	METAL CHIP	1.8K	5%	1/10W
						R359	1-216-065-91	RES-CHIP	4.7K	5%	1/10W
R209	1-216-055-00	METAL CHIP	1.8K	5%	1/10W	R362	1-216-051-00	METAL CHIP	1.2K	5%	1/10W
R210	1-216-043-91	RES-CHIP	560	5%	1/10W						
R211	1-216-071-00	METAL CHIP	8.2K	5%	1/10W	R363	1-216-079-00	METAL CHIP	18K	5%	1/10W
R212	1-216-051-00	METAL CHIP	1.2K	5%	1/10W	R364	1-216-035-00	METAL CHIP	270	5%	1/10W
R213	1-216-041-00	METAL CHIP	470	5%	1/10W	R365	1-216-109-00	METAL CHIP	330K	5%	1/10W
						R366	1-216-073-00	METAL CHIP	10K	5%	1/10W
R214	1-216-041-00	METAL CHIP	470	5%	1/10W	R367	1-216-069-00	METAL CHIP	6.8K	5%	1/10W
R215	1-216-025-11	RES-CHIP	100	5%	1/10W						
						R368	1-216-047-91	RES-CHIP	820	5%	1/10W

**MA-401**

Ref. No.	Part No.	Description	Quantity	Unit	Remark	Ref. No.	Part No.	Description	Quantity	Unit	Remark
R370	1-216-075-00	METAL CHIP	12K	5%	1/10W	R570	1-216-041-00	METAL CHIP	470	5%	1/10W
R371	1-216-079-00	METAL CHIP	18K	5%	1/10W	R571	1-216-041-00	METAL CHIP	470	5%	1/10W
R380	1-216-017-91	RES-CHIP	47	5%	1/10W	R572	1-216-041-00	METAL CHIP	470	5%	1/10W
R381	1-216-063-91	RES-CHIP	3.9K	5%	1/10W						(SE310D/SE410K/SE510)
R382	1-217-671-11	METAL CHIP	1	5%	1/10W	R574	1-216-097-11	RES-CHIP	100K	5%	1/10W
R383	1-216-031-00	METAL CHIP	180	5%	1/10W						(SE310D/SE410K/SE510)
R420	1-216-295-11	SHORT	0			R580	1-216-049-11	RES-CHIP	1K	5%	1/10W
R421	1-216-295-11	SHORT	0			R581	1-216-065-91	RES-CHIP	4.7K	5%	1/10W
R422	1-216-049-11	RES-CHIP	1K	5%	1/10W	R582	1-216-073-00	METAL CHIP	10K	5%	1/10W
R423	1-216-295-11	SHORT	0			R583	1-216-073-00	METAL CHIP	10K	5%	1/10W
R424	1-216-295-11	SHORT	0								(SE310D/SE410K/SE510)
R425	1-216-295-11	SHORT	0			R584	1-216-073-00	METAL CHIP	10K	5%	1/10W
R426	1-216-041-00	METAL CHIP	470	5%	1/10W	R585	1-216-097-11	RES-CHIP	100K	5%	1/10W
						R586	1-216-097-11	RES-CHIP	100K	5%	1/10W
R427	1-216-017-91	RES-CHIP	47	5%	1/10W						(SE310D/SE410K/SE510)
R459	1-216-089-11	RES-CHIP	47K	5%	1/10W	R587	1-216-097-11	RES-CHIP	100K	5%	1/10W
R460	1-216-073-00	METAL CHIP	10K	5%	1/10W	R590	1-216-049-11	RES-CHIP	1K	5%	1/10W
R461	1-216-037-00	METAL CHIP	330	5%	1/10W	R593	1-216-097-11	RES-CHIP	100K	5%	1/10W
R462	1-216-049-11	RES-CHIP	1K	5%	1/10W	R594	1-216-073-00	METAL CHIP	10K	5%	1/10W
R463	1-216-053-00	METAL CHIP	1.5K	5%	1/10W	R595	1-216-057-00	METAL CHIP	2.2K	5%	1/10W
R464	1-216-057-00	METAL CHIP	2.2K	5%	1/10W	R596	1-216-077-91	RES-CHIP	15K	5%	1/10W
R465	1-216-061-00	METAL CHIP	3.3K	5%	1/10W	R600	1-249-417-11	CARBON	1K	5%	1/4W F
R466	1-216-295-11	SHORT	0			R601	1-249-417-11	CARBON	1K	5%	1/4W F
R467	1-216-295-11	SHORT	0			R602	1-216-089-11	RES-CHIP	47K	5%	1/10W
R468	1-216-083-00	METAL CHIP	27K	5%	1/10W	R603	1-216-452-11	METAL OXIDE	180	5%	2W
R470	1-216-073-00	METAL CHIP	10K	5%	1/10W	R604	1-216-065-91	RES-CHIP	4.7K	5%	1/10W
R471	1-216-037-00	METAL CHIP	330	5%	1/10W	R605	1-216-065-91	RES-CHIP	4.7K	5%	1/10W
R472	1-216-049-11	RES-CHIP	1K	5%	1/10W	R606	1-216-069-00	METAL CHIP	6.8K	5%	1/10W
R473	1-216-295-11	SHORT	0			R607	1-216-053-00	METAL CHIP	1.5K	5%	1/10W
R474	1-216-063-91	RES-CHIP	3.9K	5%	1/10W	R608	1-249-414-11	CARBON	560	5%	1/4W F
R475	1-216-059-00	METAL CHIP	2.7K	5%	1/10W	R609	1-249-409-11	CARBON	220	5%	1/4W F
R476	1-216-065-91	RES-CHIP	4.7K	5%	1/10W	R610	1-249-409-11	CARBON	220	5%	1/4W F
R477	1-216-069-00	METAL CHIP	6.8K	5%	1/10W	R611	1-216-049-11	RES-CHIP	1K	5%	1/10W
R478	1-216-077-91	RES-CHIP	15K	5%	1/10W	R613	1-215-907-11	METAL OXIDE	22	5%	3W
R479	1-216-089-11	RES-CHIP	47K	5%	1/10W	R614	1-215-857-11	METAL OXIDE	10	5%	1W
											(SE310/SE510)
R500	1-216-041-00	METAL CHIP	470	5%	1/10W	R615	1-216-047-91	RES-CHIP	820	5%	1/10W
R501	1-216-041-00	METAL CHIP	470	5%	1/10W	R617	1-216-049-11	RES-CHIP	1K	5%	1/10W
R502	1-216-041-00	METAL CHIP	470	5%	1/10W	R618	1-216-055-00	METAL CHIP	1.8K	5%	1/10W
R510	1-249-407-11	CARBON	150	5%	1/4W F	R622	1-260-297-11	CARBON	2.7	5%	1/2W
						R623	1-260-073-11	CARBON	5.6	5%	1/2W
R510	1-249-408-11	CARBON	180	5%	1/4W F	R624	1-216-073-00	METAL CHIP	10K	5%	1/10W
						R625	1-216-065-91	RES-CHIP	4.7K	5%	1/10W
						R626	1-216-049-11	RES-CHIP	1K	5%	1/10W
R511	1-249-407-11	CARBON	150	5%	1/4W F	R660	1-216-049-11	RES-CHIP	1K	5%	1/10W
R512	1-216-022-00	METAL CHIP	75	5%	1/10W	R661	1-216-121-11	RES-CHIP	1M	5%	1/10W
R514	1-216-037-00	METAL CHIP	330	5%	1/10W	R662	1-216-041-00	METAL CHIP	470	5%	1/10W
R515	1-216-049-11	RES-CHIP	1K	5%	1/10W	R663	1-216-053-00	METAL CHIP	1.5K	5%	1/10W
R516	1-216-065-91	RES-CHIP	4.7K	5%	1/10W	R664	1-216-295-11	SHORT	0		
R517	1-216-022-00	METAL CHIP	75	5%	1/10W	R666	1-216-295-11	SHORT	0		
R541	1-216-025-11	RES-CHIP	100	5%	1/10W	R667	1-216-037-00	METAL CHIP	330	5%	1/10W
											(SE310D/SE410K/SE510)
R542	1-249-408-11	CARBON	180	5%	1/4W F	R668	1-216-025-11	RES-CHIP	100	5%	1/10W
						R669	1-216-025-11	RES-CHIP	100	5%	1/10W
R543	1-249-407-11	CARBON	150	5%	1/4W F	R670	1-216-041-00	METAL CHIP	470	5%	1/10W
						R671	1-216-295-11	SHORT	0		
R545	1-216-085-00	METAL CHIP	33K	5%	1/10W	R672	1-216-049-11	RES-CHIP	1K	5%	1/10W
											(SE410K/SE510: B, K)
R546	1-216-089-11	RES-CHIP	47K	5%	1/10W	R673	1-216-073-00	METAL CHIP	10K	5%	1/10W
R547	1-216-049-11	RES-CHIP	1K	5%	1/10W	R702	1-216-295-11	SHORT	0		
						R704	1-216-041-00	METAL CHIP	470	5%	1/10W
						R705	1-216-041-00	METAL CHIP	470	5%	1/10W
R548	1-216-022-00	METAL CHIP	75	5%	1/10W	R711	1-212-895-00	FUSIBLE	390	5%	1/4W
R549	1-216-022-00	METAL CHIP	75	5%	1/10W						(SE310D/SE410K/SE510)

Ref. No.	Part No.	Description	Remark	Ref. No.	Part No.	Description	Remark
R713	1-216-025-11	RES-CHIP	100 5% 1/10W	R974	1-216-081-00	METAL CHIP	22K 5% 1/10W (SE510B)
R714	1-216-113-00	METAL CHIP	470K 5% 1/10W	R975	1-216-295-11	SHORT	0 (SE510B)
R723	1-216-097-11	RES-CHIP	100K 5% 1/10W	R976	1-216-059-00	METAL CHIP	2.7K 5% 1/10W (SE510B)
R724	1-216-061-00	METAL CHIP	3.3K 5% 1/10W	R977	1-216-089-11	RES-CHIP	47K 5% 1/10W (SE510B)
R725	1-216-081-00	METAL CHIP	22K 5% 1/10W	R978	1-216-071-00	METAL CHIP	8.2K 5% 1/10W (SE510B)
R726	1-216-097-11	RES-CHIP	100K 5% 1/10W	R979	1-216-073-00	METAL CHIP	10K 5% 1/10W (SE510B)
R731	1-216-041-00	METAL CHIP	470 5% 1/10W	R980	1-216-097-11	RES-CHIP	100K 5% 1/10W (SE510B)
R733	1-216-041-00	METAL CHIP	470 5% 1/10W	R981	1-216-083-00	METAL CHIP	27K 5% 1/10W (SE510B)
R754	1-216-025-11	RES-CHIP	100 5% 1/10W	R982	1-216-089-11	RES-CHIP	47K 5% 1/10W (SE510B)
R755	1-216-025-11	RES-CHIP	100 5% 1/10W	R983	1-216-067-00	METAL CHIP	5.6K 5% 1/10W (SE510B)
R756	1-216-073-00	METAL CHIP	10K 5% 1/10W	R985	1-216-041-00	METAL CHIP	470 5% 1/10W (SE510B)
R757	1-216-049-11	RES-CHIP	1K 5% 1/10W	R986	1-216-089-11	RES-CHIP	47K 5% 1/10W (SE510B)
R800	1-216-101-00	METAL CHIP	150K 5% 1/10W (SE310/SE510)	R988	1-216-073-00	METAL CHIP	10K 5% 1/10W (SE510B)
R801	1-216-073-00	METAL CHIP	10K 5% 1/10W (SE310/SE510)	R989	1-216-049-11	RES-CHIP	1K 5% 1/10W (SE510B)
R802	1-216-073-00	METAL CHIP	10K 5% 1/10W (SE310/SE510)	R990	1-216-295-11	SHORT	0 (SE510B)
R803	1-216-081-00	METAL CHIP	22K 5% 1/10W (SE310/SE510)	R993	1-216-071-00	METAL CHIP	8.2K 5% 1/10W (SE510B)
R804	1-216-073-00	METAL CHIP	10K 5% 1/10W (SE310/SE510)	R994	1-216-689-11	METAL CHIP	39K 0.5% 1/10W (SE510B)
R805	1-216-073-00	METAL CHIP	10K 5% 1/10W (SE310/SE510)	R995	1-216-073-00	METAL CHIP	10K 5% 1/10W (SE510B)
R806	1-216-073-00	METAL CHIP	10K 5% 1/10W (SE310/SE510)	R996	1-216-689-11	METAL CHIP	39K 0.5% 1/10W (SE510B)
R807	1-216-085-00	METAL CHIP	33K 5% 1/10W (SE310/SE510)	R997	1-216-073-00	METAL CHIP	10K 5% 1/10W (SE510B)
R813	1-216-073-00	METAL CHIP	10K 5% 1/10W	R998	1-216-073-00	METAL CHIP	10K 5% 1/10W (SE510B)
R850	1-216-025-11	RES-CHIP	100 5% 1/10W (SE310/SE510)	R999	1-216-295-11	SHORT	0 (SE510B)
R851	1-216-077-91	RES-CHIP	15K 5% 1/10W (SE310/SE510)	< SWITCH >			
R852	1-216-081-00	METAL CHIP	22K 5% 1/10W (SE310/SE510)	S100	1-771-155-11	SWITCH, ROTARY (CAM ENCODER)	
R853	1-216-049-11	RES-CHIP	1K 5% 1/10W (SE310/SE510)	S101	1-571-958-11	SWITCH, PUSH (1 KEY) (REC PROOF)	
R856	1-216-097-11	RES-CHIP	100K 5% 1/10W (SE310/SE510)	S460	1-786-097-21	SWITCH, TACT (I/⊖)	
R857	1-216-069-00	METAL CHIP	6.8K 5% 1/10W (SE310/SE510)	S461	1-786-097-21	SWITCH, TACT (⊕)	
R858	1-216-069-00	METAL CHIP	6.8K 5% 1/10W (SE310/SE510)	S462	1-786-097-21	SWITCH, TACT (●)	
R859	1-216-123-11	METAL CHIP	1.2M 5% 1/10W (SE310/SE510)	S463	1-786-097-21	SWITCH, TACT (◀◀)	
R860	1-216-123-11	METAL CHIP	1.2M 5% 1/10W (SE310/SE510)	S464	1-786-097-21	SWITCH, TACT (PROGRAM +)	
R861	1-216-117-00	METAL CHIP	680K 5% 1/10W (SE310/SE510)	S470	1-786-097-21	SWITCH, TACT (■)	
R862	1-216-057-00	METAL CHIP	2.2K 5% 1/10W (SE310/SE510)	S471	1-786-097-21	SWITCH, TACT (▷)	
R968	1-216-101-00	METAL CHIP	150K 5% 1/10W (SE510B)	S473	1-786-097-21	SWITCH, TACT (▶▶)	
R969	1-216-069-00	METAL CHIP	6.8K 5% 1/10W (SE510B)	S474	1-786-097-21	SWITCH, TACT (▣)	
R970	1-216-085-00	METAL CHIP	33K 5% 1/10W (SE510B)	S476	1-786-097-21	SWITCH, TACT (PROGRAM -)	
R971	1-216-085-00	METAL CHIP	33K 5% 1/10W (SE510B)	S477	1-786-097-21	SWITCH, TACT (AUTO SET UP/RF CHANNEL)	
R972	1-216-083-00	METAL CHIP	27K 5% 1/10W (SE510B)	S478	1-786-097-21	SWITCH, TACT (SYNCHRO REC)	(SE310/SE510)
R973	1-216-105-91	RES-CHIP	220K 5% 1/10W (SE510B)	< TRANSFORMER >			
				T380	1-431-097-11	TRANSFORMER, BIAS OSCILLATION	

Ref. No.	Part No.	Description	Remark
		< TUNER >	
TU700	1-693-433-81	TUNER, IF (BTF-3MC404)	
		(SE310/SE410K/SE510: D, K)	
TU700	1-693-435-81	TUNER, IF (BTF-3MC445) (SE510B)	
		< VIBRATOR >	
X160	1-579-463-11	VIBRATOR, CRYSTAL (32.768kHz)	
X161	1-781-717-21	VIBRATOR, CRYSTAL (17.734475MHz)	
X200	1-579-608-21	VIBRATOR, CRYSTAL (4.43MHz)	
		<b>*****</b>	
*	1-468-459-11	POWER BLOCK (ETXNY272E2D)	
		*****	
		(Ref.No. 2,000 Series)	
		< CAPACITOR >	
△C001	9-885-001-95	PLASTIC FILM 0.047uF	250V
△C002	9-885-001-96	PLASTIC FILM 0.1uF	250V
△C003	9-885-001-97	ELECT 47uF	400V
△C004	9-885-001-98	CERAMIC 3300pF	250V
△C005	9-885-001-98	CERAMIC 3300pF	250V
△C006	9-885-001-99	CERAMIC 470pF	250V
△C007	9-885-001-99	CERAMIC 470pF	250V
C102	1-126-964-91	ELECT 10uF	50V
C103	9-885-002-00	CERAMIC 470pF	50V
C104	9-885-002-01	PLASTIC FILM 1.5nF	5% 50V
C105	9-885-002-02	PLASTIC FILM 220nF	63V
C106	9-885-002-03	PLASTIC FILM 100nH	83V
C107	1-126-965-91	ELECT 22uF	50V
C201	1-126-968-91	ELECT 100uF	50V
C301	9-880-907-01	ELECT 820uF	25V
C302	1-126-968-91	ELECT 100uF	50V
C303	9-885-002-04	PLASTIC FILM 10nF	83V
C401	9-880-908-01	ELECT 820uF	16V
C402	1-126-925-91	ELECT 470uF	10V
C403	9-885-002-04	PLASTIC FILM 10nF	83V
C501	1-126-960-91	ELECT 1uF	50V
C601	9-880-909-01	ELECT 330uF	25V
		< CONNECTOR >	
CN001	1-580-230-11	CONNECTOR 2P	
CN101	1-784-642-11	CONNECTOR 11P	
		< DIODE >	
D001	9-885-002-05	DIODE 1N4007	
D002	9-885-002-05	DIODE 1N4007	
D003	9-885-002-05	DIODE 1N4007	
D004	9-885-002-05	DIODE 1N4007	
D101	9-885-002-06	DIODE 1SS133T-77	
D102	9-885-002-07	DIODE ERA91-02V3	
D103	9-885-002-05	DIODE 1N4007	
D104	9-885-002-06	DIODE 1SS133T-77	
D201	9-885-002-05	DIODE 1N4007	
D301	9-880-915-01	DIODE FE3C	
D401	9-885-002-08	DIODE ERB83-006V3	
D601	9-885-002-07	DIODE ERA91-02V3	

Ref. No.	Part No.	Description	Remark
		< FUSE >	
△F001	9-884-454-01	FUSE (2A/250V)	
		< IC >	
△IC101	9-885-002-09	IC uC3844A	
IC501	9-880-920-01	IC KA431AZTA	
		< COIL >	
△L001	9-885-002-10	LINE FILTER 60uH	3.0A
△L002	9-885-002-11	LINE FILTER 26mH	0.4A
L101	9-885-002-12	FERRITE BEAD INDUCTOR	
L201	9-885-002-12	FERRITE BEAD INDUCTOR	
L301	9-885-002-13	CHOKE 3.3uH	2.2A
L302	9-885-002-12	FERRITE BEAD INDUCTOR	
L401	9-885-002-13	CHOKE 3.3uH	2.2A
		< ISOLATOR >	
△PC101	9-880-921-01	OPTOISOLATOR	
		< TRANSISTOR >	
△Q101	9-880-922-01	POWER FET	
Q102	9-885-002-14	TRANSISTOR 2SC3311A-QTA	
		< RESISTOR >	
△R001	9-885-002-15	CARBON FILM 2M	1/2W
R101	1-247-882-91	CARBON FILM 130K	1/4W
R102	1-247-882-91	CARBON FILM 130K	1/4W
R103	1-247-882-91	CARBON FILM 130K	1/4W
R104	1-247-882-91	CARBON FILM 130K	1/4W
R105	9-885-002-16	METAL FILM 4.7	1/2W
R107	9-885-002-17	METAL FILM 0.75	1/2W
R110	1-214-761-11	METAL FILM 22K	1% 1/4W
R111	1-247-855-91	CARBON FILM 10K	1/4W
R112	1-247-831-91	CARBON FILM 1K	1/4W
R113	1-247-807-91	CARBON FILM 100	1/4W
R201	1-247-879-91	CARBON FILM 100K	1/4W
R218	1-247-839-91	CARBON FILM 2.2K	1/4W
R301	1-247-829-91	CARBON FILM 820	1/4W
R501	1-214-729-11	METAL FILM 1K	1% 1/4W
R502	9-885-002-18	METAL FILM 1.4K	1% 1/4W
R503	1-247-799-91	CARBON FILM 47	1/4W
R504	1-247-851-91	CARBON FILM 6.8K	1/4W
R505	1-247-837-91	CARBON FILM 1.8K	1/4W
R601	1-247-879-91	CARBON FILM 100K	1/4W
		< TRANSFORMER >	
△T101	9-885-002-19	SWITCHING TRANSFORMER	
		< VARISTOR >	
△Z001	9-880-923-01	METALOXID-VARISTOR 750V	D=10
		< ZENER DIODE >	
ZD101	9-880-924-01	ZENER DIODE 0.4W	5.1V
ZD102	9-885-002-20	ZENER DIODE 0.4W	27V
ZD103	9-880-926-01	VOLTAGE SUPPRESSOR 600W	350V

The components identified by mark △ or dotted line with mark △ are critical for safety. Replace only with part number specified.



Ref. No.	Part No.	Description	Remark
		KK-26 BOARD, COMPLETE *****	(Ref.No. 1,000 Series)

< SWITCH >

S410	1-418-156-11	ENCODER, ROTARYRY (DIAL TIMER)	
------	--------------	--------------------------------	--

MISCELLANEOUS  
\*\*\*\*\*

53	1-792-018-11	CABLE, FLAT (FAC-8)	
54	1-792-019-11	CABLE, FLAT (FFM-36)	
△ 57	1-782-012-22	CORD, POWER	
704	1-500-471-11	HEAD, FE	
721	A-6775-791-A	ACE BLOCK ASSY (EURO 3)	
770	1-772-361-11	DRUM ASSY, DZH-92D-R (SE310)	
770	1-772-362-11	DRUM ASSY, DZH-93D-R (SE410/SE510)	
M902	1-698-971-11	MOTOR, DC (CAPSTAN)	
M903	X-3947-577-1	MOTOR ASSY, CAM	

\*\*\*\*\*  
HARDWARE LIST  
\*\*\*\*\*

#1	7-685-648-79	SCREW +BVTP 3X12 TYPE2	
#3	7-685-646-79	SCREW +BVTP 3X8 TYPE2	
#4	7-682-147-01	SCREW +P 3X6	
#5	7-685-133-19	SCREW (DIA. 2.6) (IT3B)	

ACCESSORIES & PACKING MATERIALS  
\*\*\*\*\*

	1-418-008-31	COMMANDER, STANDARD (RMT-V257B) (SE310/SE410/SE510: D, K)	
	1-418-008-41	COMMANDER, STANDARD (RMT-V257C) (SE510B)	
△	1-770-019-11	ADAPTOR, CONVERSION PLUG 3P (SE310I)	
	1-790-419-11	CORD, CONNECTION (PAL)	
	3-065-669-11	MANUAL, INSTRUCTION (FRENCH) (SE310D/SE510D)	
	3-065-669-21	MANUAL, INSTRUCTION (SPANISH) (SE310D/SE510D)	
	3-065-669-31	MANUAL, INSTRUCTION (GERMAN) (SE310D/SE510D)	
	3-065-669-41	MANUAL, INSTRUCTION (ITALIAN) (SE510D)	
	3-065-669-51	MANUAL, INSTRUCTION (DUTCH) (SE310D/SE510D)	
	3-065-669-61	MANUAL, INSTRUCTION (PORTUGUESE) (SE310D/SE510D)	
	3-065-669-71	MANUAL, INSTRUCTION (GREEK) (SE510D)	
	3-065-670-11	MANUAL, INSTRUCTION (SWEDISH) (SE310D)	
	3-065-670-21	MANUAL, INSTRUCTION (DANISH) (SE310D)	
	3-065-670-31	MANUAL, INSTRUCTION (FINNISH) (SE310D)	
	3-065-671-11	MANUAL, INSTRUCTION (FRENCH) (SE510B)	
	3-065-672-11	MANUAL, INSTRUCTION (ENGLISH) (SE310I)	
	3-065-673-11	MANUAL, INSTRUCTION (ENGLISH) (SE410/SE510K)	
	3-065-673-21	MANUAL, INSTRUCTION (CZECH) (SE410/SE510K)	

Ref. No.	Part No.	Description	Remark
	3-065-673-31	MANUAL, INSTRUCTION (POLISH) (SE410/SE510K)	
	3-065-673-41	MANUAL, INSTRUCTION (HUNGARIAN)	
	3-065-673-51	MANUAL, INSTRUCTION (RUSSIAN) (SE410)	

The components identified by mark △ or dotted line with mark △ are critical for safety. Replace only with part number specified.

